

FAB

SUPPLY

INCORPORATED



Press Brake Tooling

Rolla-V Product Range

WWW.FABSUPPLYINC.COM

Technical Spec.

The Rolla-V Range of Tools

Rolla-V dies are available to suit any manufacturer's machine.

Several fixed sizes are offered as well as adjustable models which are ideal for heavy plate or large radius work.

Appropriate insert materials are used to suit the typical applications for each size Rolla-V tool, although custom materials may be available on request.

Custom sizes and widths are also available for specific applications. Please call us to find out more.



Non-Standard lengths are available to order on all models

APPLICATION

RVP (models 1, 2 and 3) are 60mm clamping widths
Suitable for Amada, Atlantic, Adira, Bystronic Euro, Beyeler Euro-B, CR Electronic, Durmazlar, Ermaskan, Gasparini, Guifil, Haco, Promecam.

RVS (models 1, 2) are 14mm tang
Suitable for Amada style single V holder.

RVT (models 1, 2 and 3) are 12.7mm/13.0mm tang
Suitable for Bystronic, Hammerle, Beyeler, Edwards, Safan, SMB, Trumpf.

RVT90 (models 1, 2 and 3) are 12.7mm offset tang
Suitable for LVD with offset tang

RVM (models 2.5, 3, 3.5 and 4)
Universal clamping with base or tang - all styles are available - suitable for any machine brand.

If you cannot see your machine type listed here we can provide advice and make custom fittings to your specification - please call us.

ROLLA-V MATERIALS

Inserts	All models	Through hardened up to HRc60. 70 Rockwell available on request.
Body	All models	42CrMo4 tensile strength 1100-1200M/mm ² surface hardened to HRC55

Non-standard insert materials and HRc values are available for specific applications - please call us

Advantages of Using Rolla-V

- Highly precision ground
- Modular
- Avoid traditional bending marks
- Minimal marking
- Extremely short flanges possible
- No tool material cross contamination
- Bend close to holes and cut-outs with no deformation
- Fewer tool changes
- Bends laser cut sheets with no tool damage
- Ideal for radius bending
- Exact inside radius
- Ideal for tapped or feathered edges
- Bends up to 30mm thick material (subject to model selected)

APPLICATION AND TECHNICAL DATA

APPLICATION AND TECHNICAL DATA SHEET					
MODEL	Max Load Capacity	Material Thickness	Min. Bend Angle	Min. Outside Flange	Max Outside Radius
XT1	50t/m (17tn/ft)	0.3mm (.012")	60°	3.2mm (.126")	2.2mm (.087")
Equivalent vee size - 4.57mm (.180")	50t/m (17tn/ft)	0.8mm (.031")	60°	3.2mm (.126")	2.2mm (.087")
Vee gap at 90° - .9mm (.035")	50t/m (17tn/ft)	1.2mm (.047")	60°	3.2mm (.126")	2.2mm (.087")
XT2	70t/m (24tn/ft)	0.5mm (.020")	60°	6.1mm (.240")	4.1mm (.161")
Equivalent vee size - 8.66mm (.341")	70t/m (24tn/ft)	1.0mm (.039")	60°	6.1mm (.240")	4.1mm (.161")
Vee gap at 90° - 1.9mm (.075")	70t/m (24tn/ft)	2.0mm (.079")	60°	6.1mm (.240")	4.1mm (.161")
MODEL 1	100t/m (34tn/ft)	0.7mm (.028")	40°	4.2mm (.165")	3.0mm (.118")
Equivalent vee size - 6.59mm (.259")	100t/m (34tn/ft)	1.1mm (.043")	35°	4.2mm (.165")	2.6mm (.102")
Vee gap at 90° - 1.6mm (.063")	100t/m (34tn/ft)	1.5mm (.059")	35°	4.2mm (.165")	2.2mm (.087")
MODEL 2	150t/m (50tn/ft)	2.0mm (.079")	59°	9.3mm (.366")	6.0mm (.236")
Equivalent vee size - 13.16mm (.518")	150t/m (50tn/ft)	3.0mm (.118")	47°	9.3mm (.366")	5.0mm (.197")
Vee gap at 90° - 3.5mm (.138")	150t/m (50tn/ft)	3.2mm (.126")	47°	9.3mm (.366")	4.8mm (.189")
MODEL 2.5	250t/m (84tn/ft)	2.0mm (.079")	46°	18.6mm (.732")	13.2mm (.520")
Equivalent vee size - 25.17mm (1.0")	250t/m (84tn/ft)	4.0mm (.157")	46°	18.6mm (.732")	12.0mm (.472")
Vee gap at 90° - 7.5mm (.300")	250t/m (84tn/ft)	5.0mm (.196")	55°	18.6mm (.732")	10.8mm (.425")
MODEL 3 GEN 1	250t/m (84tn/ft)	3.0mm (.118")	75°	27.5mm (1.082")	23.0mm (.905")
Equivalent vee size - 36mm (1.42")	250t/m (84tn/ft)	4.0mm (.157")	75°	27.5mm (1.082")	22.0mm (.866")
Vee gap at 90° - 13.3mm (.524")	250t/m (84tn/ft)	6.4mm (.252")	75°	27.5mm (1.082")	19.5mm (.768")
MODEL 3 GEN 2	250t/m (84tn/ft)	2.0mm (.079")	68°	22.5mm (.886")	13.9mm (.547")
Equivalent vee size - 30.22mm (1.19")	250t/m (84tn/ft)	4.0mm (.157")	50°	22.5mm (.886")	11.9mm (.469")
Vee gap at 90° - 6.5mm (.256")	250t/m (84tn/ft)	6.4mm (.252")	50°	22.5mm (.886")	9.5mm (.374")
MODEL 3.5	250t/m (84tn/ft)	6.0mm (.236")	75°	39.0mm (1.535")	20.0mm (.787")
Equivalent vee size - 55.05mm (2.17")	250t/m (84tn/ft)	8.0mm (.315")	75°	39.0mm (1.535")	20.0mm (.787")
Vee gap at 90° - 18.6MM (.732")	250t/m (84tn/ft)	10.0mm (.394")	75°	39.0mm (1.535")	20.0mm (.787")
MODEL 4	300t/m (101tn/ft)	6.0mm (.236")	78°	56.6mm (2.228")	36.4mm (1.433")
Equivalent vee size - 76.51mm (3.01")	300t/m (101tn/ft)	8.0mm (.315")	76°	56.6mm (2.228")	36.4mm (1.433")
Vee gap at 90° - 32.9mm (1.30")	300t/m (101tn/ft)	12.7mm (.500")	73°	56.6mm (2.228")	36.4mm (1.433")

Adjustable models	Min / Max (mm)	Max Load (t)
RVHD2	16 - 30 (.630-1.181")	200 (67t/ft)
RVHD2.5	28 - 69 (1.102-2.717")	250 (84t/ft)
RVHD3	38 - 110 (1.496-4.311")	350 (118t/ft)
RVHD4	69 - 220 (2.717-8.661")	350 (118t/ft)

Adjustables are usually used for bending thick materials or for bending large radii - because specific material specs vary we do not provide detailed bend data. Flaring or hole distortion is much reduced, but is influenced by material specification. Radius work is greatly affected by spring-back of the specific material being bent. Minimum flange sizes are greatly affected by the squareness of the component edge.

For thinner gauge material

- Thickness
0.3mm - 1.2mm (.012-.047")
- Standard Lengths
50mm , 100mm, 200mm and 500mm
- Minimum Flange
3.2mm (.126")
- Maximum Capacity
50 Tonnes (55tn)

The latest addition to the Rolla-V family - The XT1 and XT2 are specifically made for thinner gauge material.

These tools are ideal for thin materials with short flanges or intricate components .

	max. load capacity (t/m)	material thickness (mm)	min. bending angle	min. outside flange (mm)	max. outside radius (mm)
Model XT1 fixed style	50 (17tn/ft)	0.3 (.012")	60°	3.2 (.126")	2.2 (.087")
	50 (17tn/ft)	0.8 (.031")	60°	3.2 (.126")	2.2 (.087")
	50 (17tn/ft)	1.2 (.047")	60°	3.2 (.126")	2.2 (.087")

Equivalent V size 4.57mm (.180")

XT1

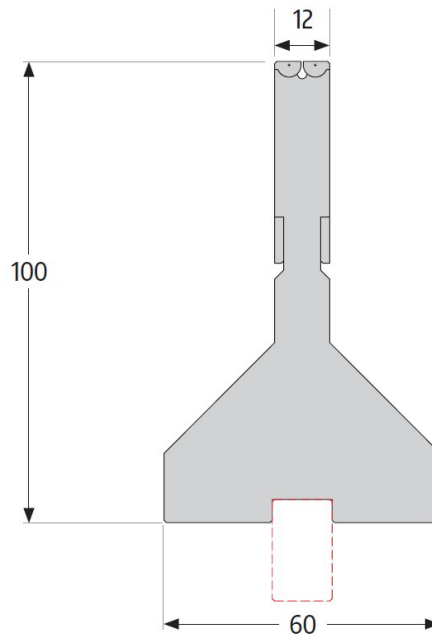

500mm 5.5 kg (12lbs)
100mm 1.0 kg (2lbs)

XT2

For thinner gauge material

- Thickness
0.5mm - 2.0mm (.020-.079")
- Standard Lengths
50mm , 100mm, 200mm and 500mm
- Minimum Flange
6.1mm (.240")
- Maximum Capacity
70 Tonnes (77tn)

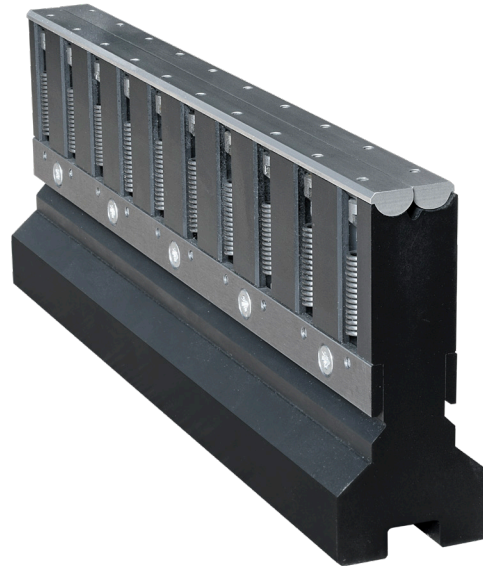

	max. load capacity (t/m)	material thickness (mm)	min. bending angle	min. outside flange (mm)	max. outside radius (mm)
--	--------------------------	-------------------------	--------------------	--------------------------	--------------------------

Model XT2 fixed style	70 (24tn/ft)	0.5 (.020")	60°	6.1 (.240")	4.1 (.161")
	70 (24tn/ft)	1.0 (.039")	60°	6.1 (.240")	4.1 (.161")
	70 (24tn/ft)	2.0 (.079")	60°	6.1 (.240")	4.1 (.161")

Equivalent V size 8.66mm (.341")

XT2

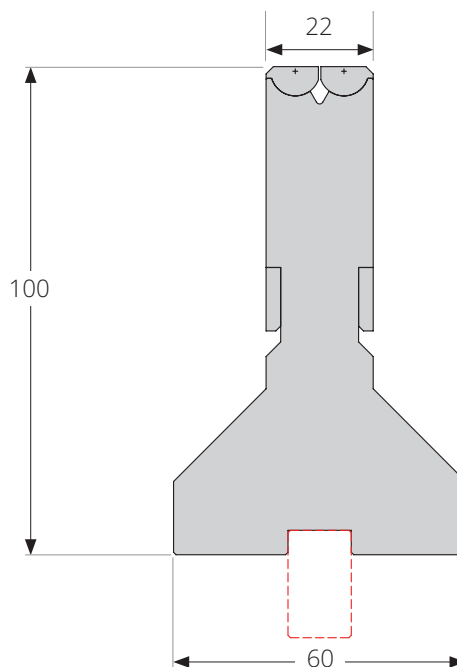

500mm	8.0 kg (18lbs)
100mm	1.6 kg (4lbs)

Model 1

■ Castellated inserts to give more contact area

■ **Standard Lengths**

500mm, 100mm and 440mm segmented

■ **Segmented**

440mm lengths include: 200mm, 100mm, 50mm, 30mm, 25mm, 20mm, 15mm

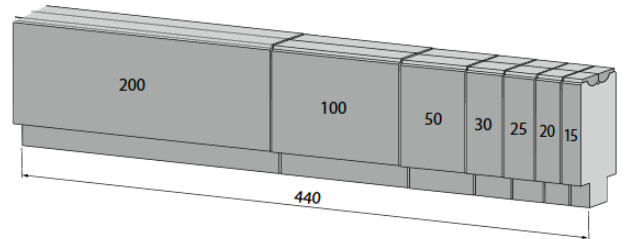

	max. load capacity (t/m)	material thickness (mm)	min. bending angle	min. outside flange (mm)	max. outside radius (mm)
--	--------------------------	-------------------------	--------------------	--------------------------	--------------------------

Model 1 fixed style	100 (34tn/ft)	0.7 (.028")	40°	4.2 (.165")	3.0 (.118")
	100 (34tn/ft)	1.1 (.043")	35°	4.2 (.165")	2.6 (.102")
	100 (34tn/ft)	1.5 (.059")	35°	4.2 (.165")	2.2 (.087")

Equivalent V size 6.59mm (.259")

RVP60- 1

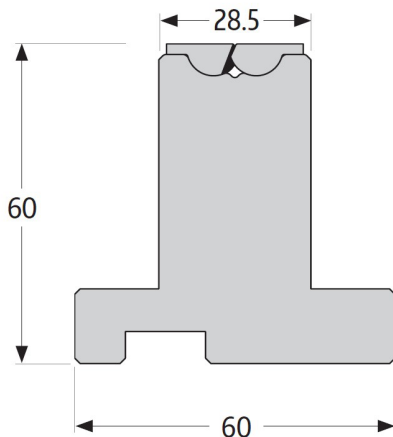

500mm	6.9 kg (15lbs)
440mm segmented	6.1 kg (13lbs)
100mm	1.4 kg (3lbs)

RVS80- 1

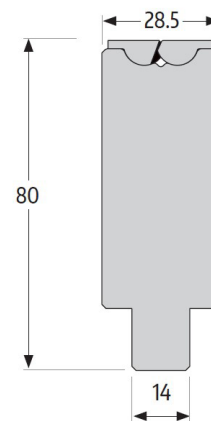

500mm	6.3 kg (14lbs)
440mm segmented	5.8 kg (13lbs)
100mm	1.3 kg (3lbs)

Model 1



RVT55- 1

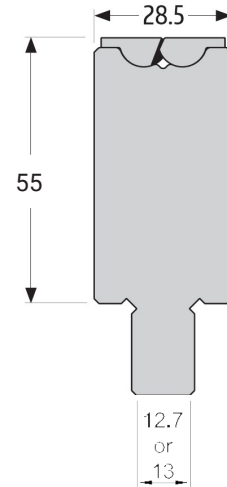

500mm
440mm segmented
100mm

5.5 kg (12lbs)
5.0 kg (11lbs)
1.1 kg (2lbs)

RVT90- 1

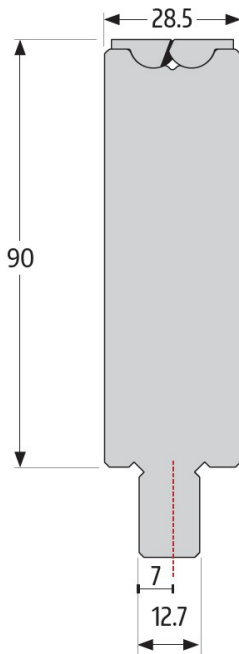

500mm
440mm segmented
100mm

8.5 kg (19lbs)
7.8 kg (17lbs)
1.7 kg (4lbs)

RVT100- 1

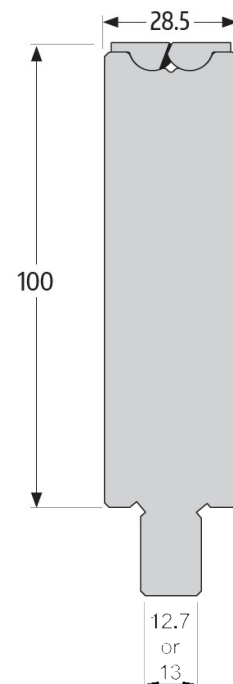

500mm
440mm segmented
100mm

9.4 kg (21lbs)
8.6 kg (19lbs)
1.8 kg (4lbs)

Model 2

Standard Lengths

500mm, 250mm, 100mm and 450 segmented

Segmented

450mm lengths include: 200mm, 100mm, 40mm, 35mm, 30mm, 25mm, 20mm

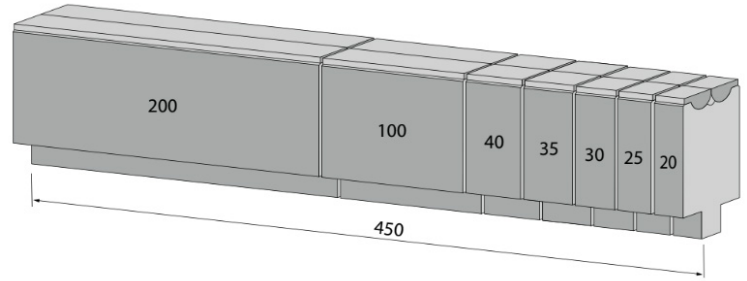

	max. load capacity (t/m)	material thickness (mm)	min. bending angle	min. outside flange (mm)	max. outside radius (mm)
Model 2 fixed style	150 (50tn/ft)	2.0 (.079")	59°	9.3 (.336")	6.0 (.226")
	150 (50tn/ft)	3.0 (.118")	47°	9.3 (.336")	5.0 (.197")
	150 (50tn/ft)	3.2 (.126")	47°	9.3 (.336")	4.8 (.189")

Equivalent V size 13.16mm (.518")

RVP65- 2

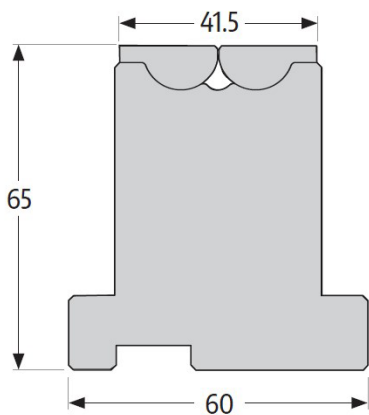

500mm 7.9 kg (17lbs)
 450mm segmented 7.4 kg (16lbs)
 100mm 1.6 kg (4lbs)

RVS80- 2

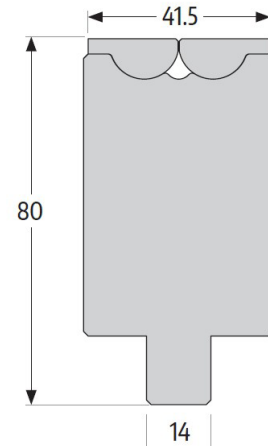

500mm 8.3 kg (18lbs)
 470mm segmented 7.8 kg (17lbs)
 100mm 1.7 kg (4lbs)

Model 2



RVT60- 2

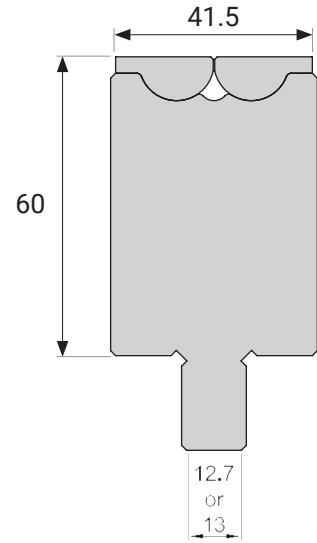

500mm	7.9 kg (17lbs)
450mm segmented	7.4 kg (16lbs)
100mm	1.6 kg (4lbs)

RVT90- 2

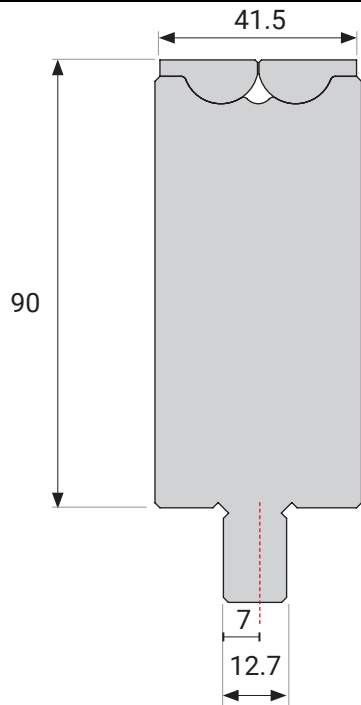

500mm	11.3 kg (25lbs)
450mm segmented	10.6 kg (23lbs)
100mm	2.2 kg (5lbs)

RVT100- 2

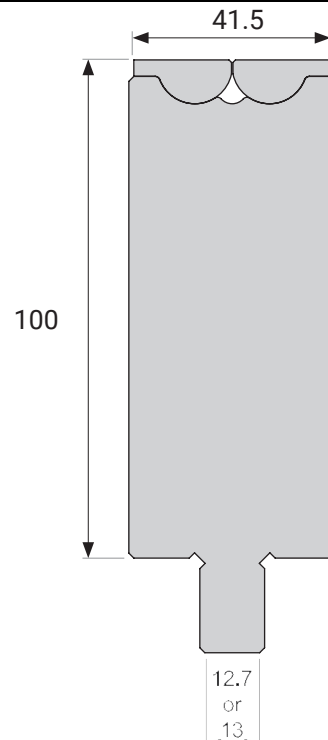

500mm	12.4 kg (27lbs)
450mm segmented	11.7 kg (26lbs)
100mm	2.5 kg (6lbs)

Model 2.5

Standard Lengths

500mm, 250mm and 470mm segmented

Segmented

470mm lengths include: 200mm, 100mm, 50mm, 45mm, 40mm, 35mm

Tang Sizes

60mm, 13mm, 12.7mm, 12.7mm offset

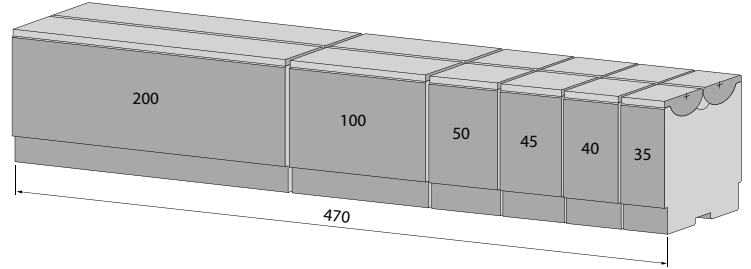

	max. load capacity (t/m)	material thickness (mm)	min. bending angle	min. outside flange (mm)	max. outside radius (mm)
Model 2.5 fixed style	250 (84tn/ft)	2.0 (.079")	46°	18.6 (.732")	13.2 (.520")
	250 (84tn/ft)	4.0 (.157")	46°	18.6 (.732")	12.0 (.472")
	250 (84tn/ft)	5.0 (.236")	55°	18.6 (.732")	10.8 (.425")

Equivalent V size 25.17mm (1.0")

RVM- 2.5

Available with any
base or Tang Fitting

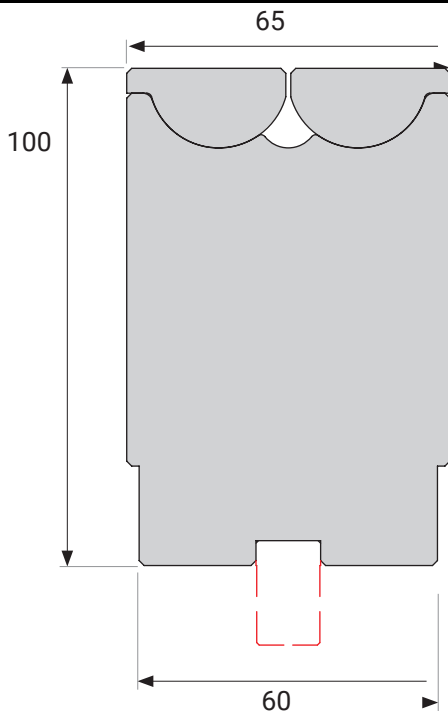

500mm
470mm segmented
100mm

22.0 kg (48lbs)
21.0 kg (46lbs)
4.4 kg (10lbs)

Model 2.5



On-site

Demonstrations available



You will be able to test our tools on site and find out exactly how our range can work for you. For more details please call us at 866.322.8665

Model 3

Standard Lengths

500mm, 250mm and 550mm segmented

Segmented

550mm lengths include: 30mm, 35mm, 40mm, 45mm, 50mm, 50mm, 100mm, 200mm



	max. load capacity (t/m)	material thickness (mm)	min. bending angle	min. outside flange (mm)	max. outside radius (mm)
Model 3 Generation 1	250 (84tn/ft)	3.0 (.118")	75°	27.5 (1.082")	23.0 (.905")
	250 (84tn/ft)	4.0 (.157")	75°	27.5 (1.082")	22.0 (.866")
	250 (84tn/ft)	6.4 (.252")	75°	27.5 (1.082")	19.5 (.768")

Equivalent V size 36mm (1.42")

Generation 1

RVP60

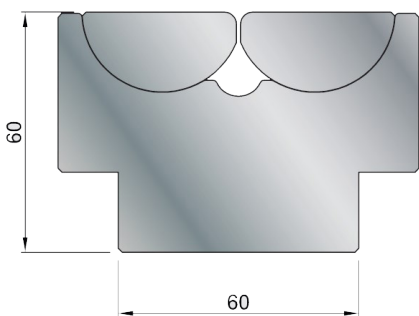

500mm
455mm segmented

28.8 kg (63lbs)
26.2 kg (58lbs)

RVT55

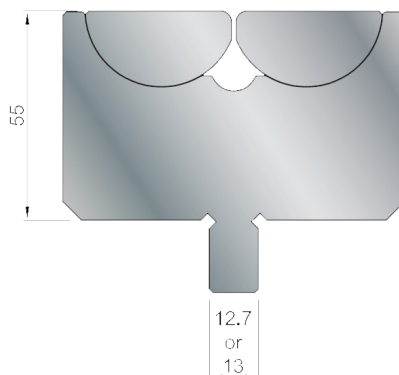

500mm
455mm segmented

20.6 kg (45lbs)
18.7 kg (41lbs)

RVT100

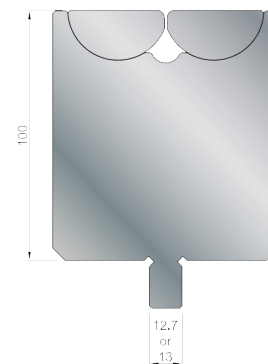

500mm
455mm segmented

30.9 kg (68lbs)
28.5 kg (63lbs)

Model 3

Standard Lengths

500mm, 250mm and 455 segmented

Segmented

455mm lengths include: 200mm, 100mm, 60mm, 50mm, 45mm

Tang Sizes - RVM70-3

60mm, 13mm, 12.7mm, 12.7mm offset

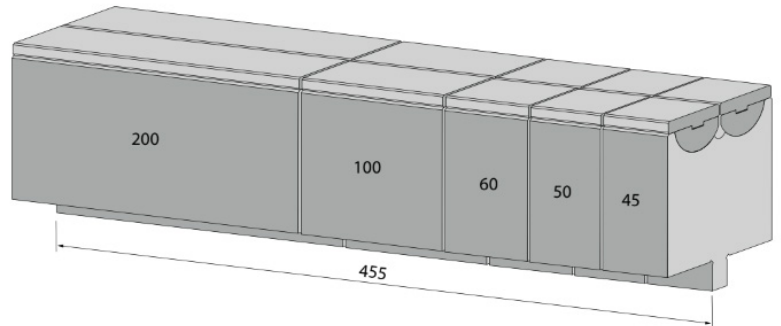

	max. load capacity (t/m)	material thickness (mm)	min. bending angle	min. outside flange (mm)	max. outside radius (mm)
Model 3 Generation 2	250 (84tn/ft)	2.0 (.079")	68°	22.5 (.866")	13.9 (.547")
	250 (84tn/ft)	4.0 (.157")	50°	22.5 (.866")	11.9 (.469")
	250 (84tn/ft)	6.4 (.252")	50°	22.5 (.866")	9.5 (.374")

Equivalent V size 30.22mm (1.19")

Generation 2

RVP100-3

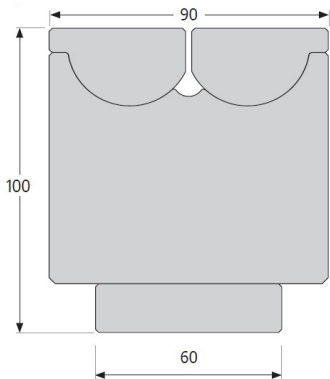

500mm
455mm segmented
100mm

28.8 kg (63lbs)
26.2 kg (58lbs)
5.8 kg (13lbs)

RVT100-3

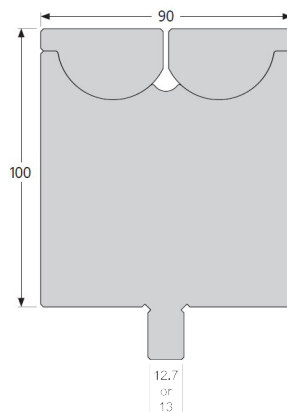

500mm
455mm segmented
100mm

30.9 kg (68lbs)
28.5 kg (63lbs)
6.2 kg (14lbs)

RVM70-3

Available with any base or Tang Fitting

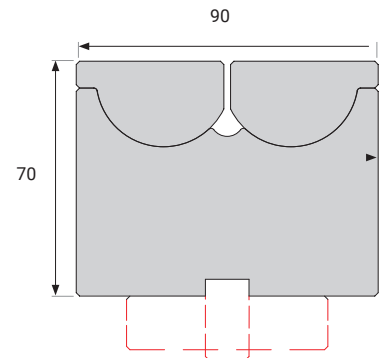

500mm
455mm segmented
100mm

20.6 kg (45lbs)
18.7 kg (41lbs)
4.2 kg (9lbs)

Model 3.5

■ **Tang Fittings**

Available to suit all manufacturers' machines

■ **Standard Lengths**

500mm and 250mm

■ **Tang Sizes**

60mm, 13mm, 12.7mm, 12.7mm offset



	max. load capacity (t/m)	material thickness (mm)	min. bending angle	min. outside flange (mm)	max. outside radius (mm)
Model 3.5 fixed style	250 (84tn/ft)	6.0 (.236")	75°	39.0 (1.535")	20.0 (.787")
	250 (84tn/ft)	8.0 (.315")	75°	39.0 (1.535")	20.0 (.787")
	250 (84tn/ft)	10.0 (.394")	75°	39.0 (1.535")	20.0 (.787")

Equivalent V size 55.05mm (2.17")

RVM- 3.5

Available with any base or Tang Fitting

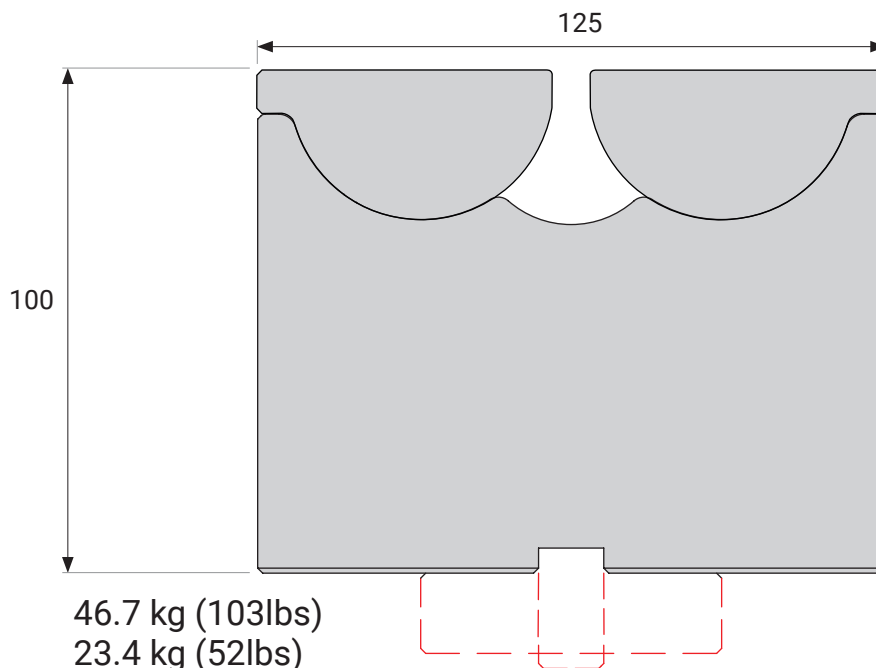

500mm 46.7 kg (103lbs)
 250mm 23.4 kg (52lbs)

Please remember to order your required Tang.

Model 4

■ **Tang Fittings**

Available to suit all manufacturers' machines

■ **Standard Lengths**

500mm and 250mm

■ **Tang Sizes**

60mm, 13mm, 12.7mm, 12.7mm offset

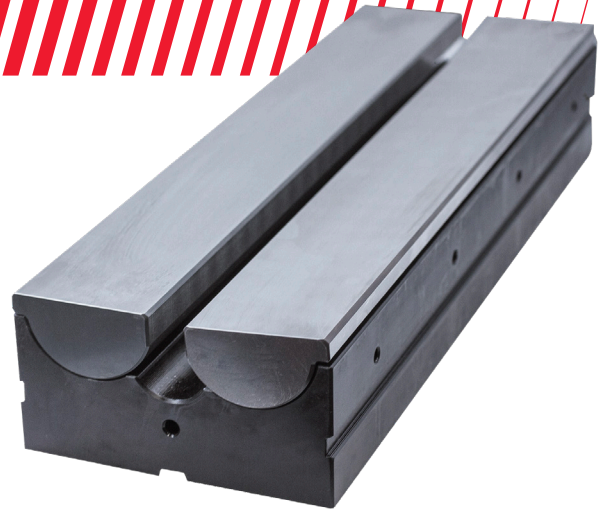

	max. load capacity (t/m)	material thickness (mm)	min. bending angle	min. outside flange (mm)	max. outside radius (mm)
Model 4 fixed style	300 (101tn/ft)	6.0 (.236")	78°	56.6 (2.228")	36.4 (1.433")
	300 (101tn/ft)	8.0 (.315")	76°	56.6 (2.228")	36.4 (1.433")
	300 (101tn/ft)	12.7 (.500")	73°	56.6 (2.228")	36.4 (1.433")

Equivalent V size 76.51mm (3.01")

RVM90- 4

Available with any base or Tang Fitting

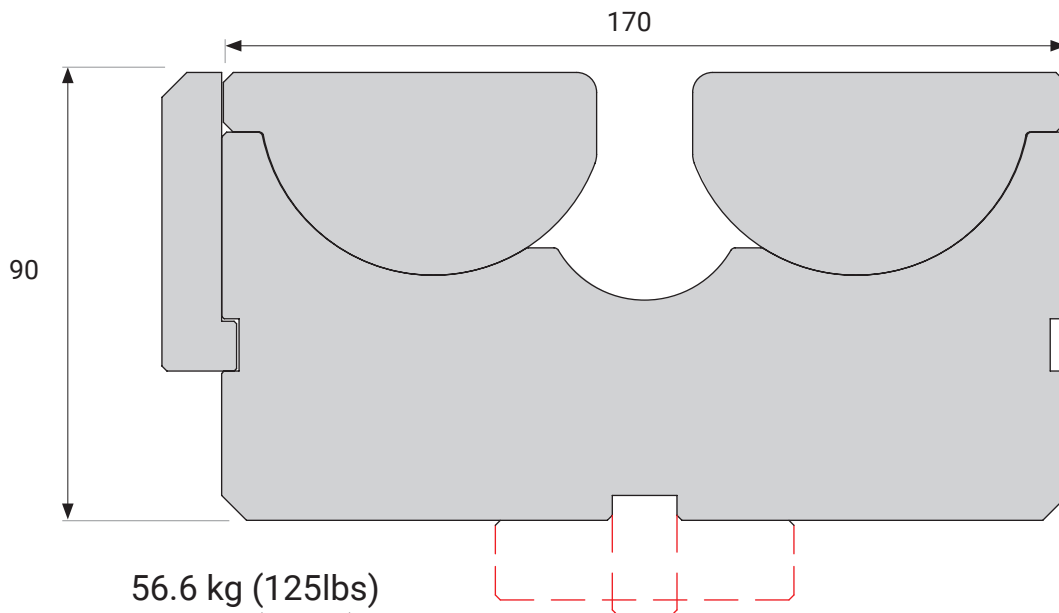

500mm
250mm

56.6 kg (125lbs)
28.3 kg (62lbs)

Please remember to order your required Tang.

Applications

Special Rolla-V range

Hemming & Joggle (Z) Tools

- Achieve a small flange and minimize safety edge marking using the Rolla-V Hemming Tool
- Minimize Joggle Form marking
- Large range of Z folds available from one tool
- Contact us if you have special applications

These products are made to order your to specification.

Please call to discuss your individual requirements.

Hemming Tool

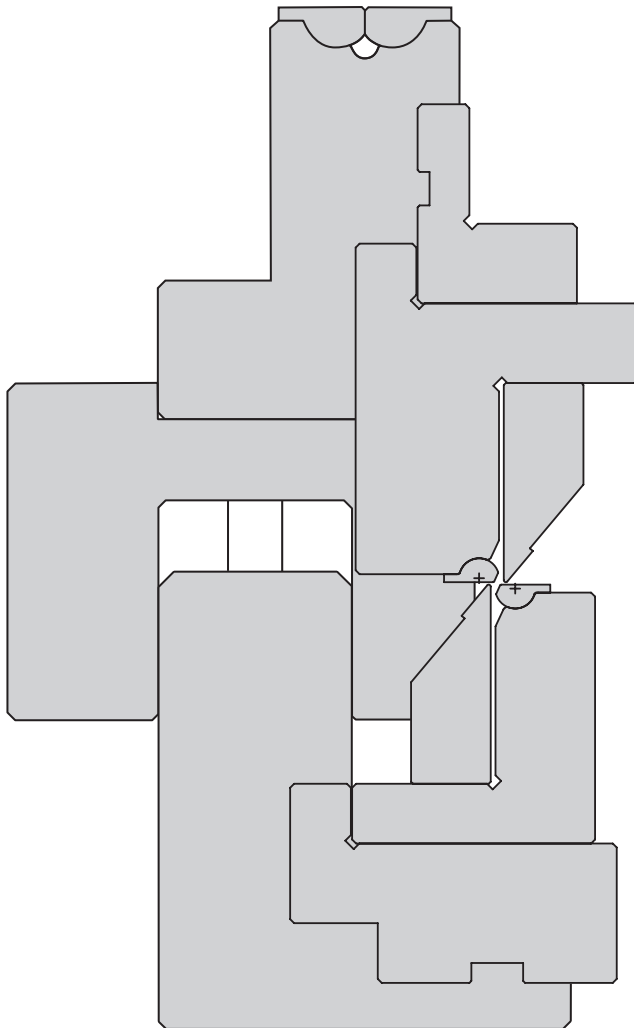

Adjustable Joggle

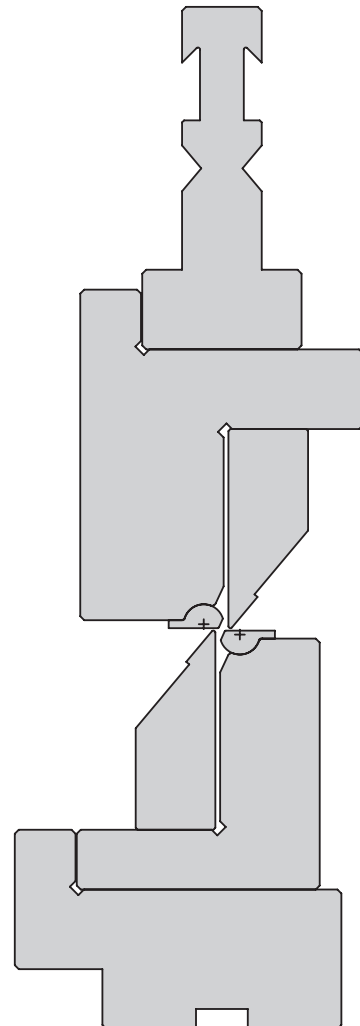

Squaring Arm

Magnetic

- Easy and fast positioning anywhere on the bottom dies
- Precise and flexible adjustability
- Adjustable angle stop/adjustment
- Mountable on all dies
- Ideal for long and thin sheet metals
- No obtrusive clamps
- Powerful magnets
- Laser marked angles
- Health and safety compliant



Adjustable

Rolla-V Range

Non-standard lengths available to order

- Several fixed sizes are offered as well as adjustable models which are ideal for heavy plate or large radius work.
- Standard lengths 500mm and 250mm
- These tools are usually used for bending thicker materials or making large radius components.
- Specific material specifications vary greatly so it is not feasible to provide detailed data

eg. minimum flange sizes are greatly affected by squareness of component edge

eg. flaring or hole distortion is much reduced with these tools, but is influenced by specific material type

eg. radius work is greatly affected by springback of specific material and flange sizes

Please call us to discuss specific applications!

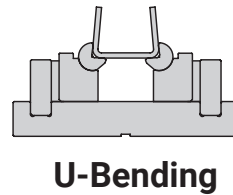
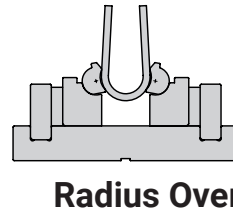
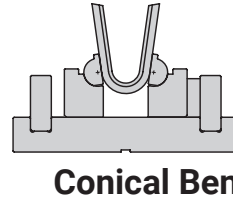
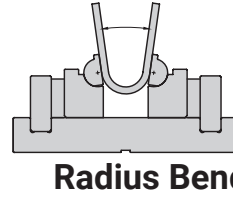
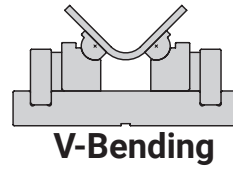

RVHD2

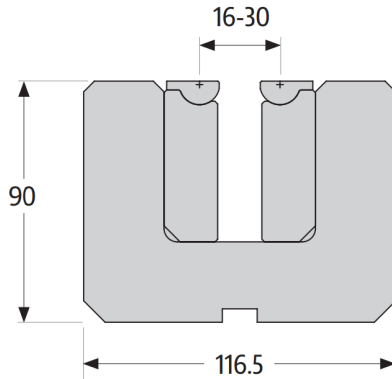

500mm 33.6 kg (74lbs)
250mm 16.8 kg (37lbs)

Maximum recommended thickness 5mm

RVHD2.5

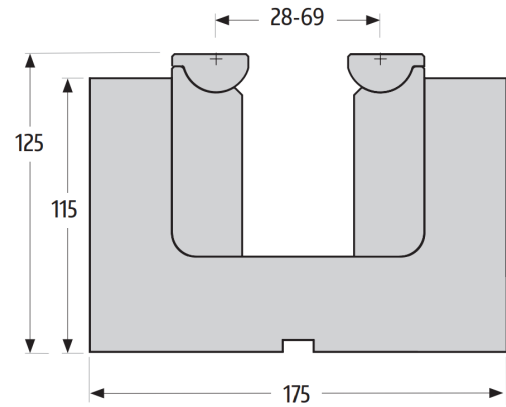

500mm 67.5 kg (149lbs)
250mm 33.8 kg (75lbs)

Maximum recommended thickness 10mm

Adjustable

Rolla-V Range

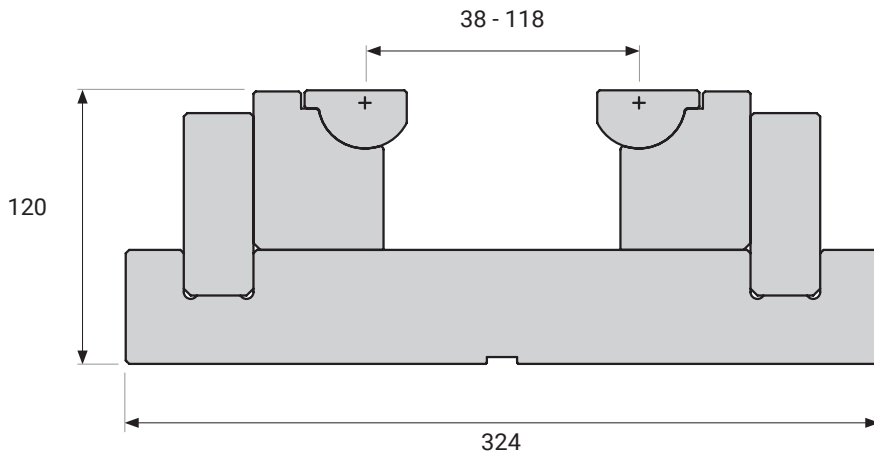

RVHD3

500mm	98.0 kg (216lbs)
250mm	49.0 kg (108lbs)

Maximum recommended thickness
20mm (.787")

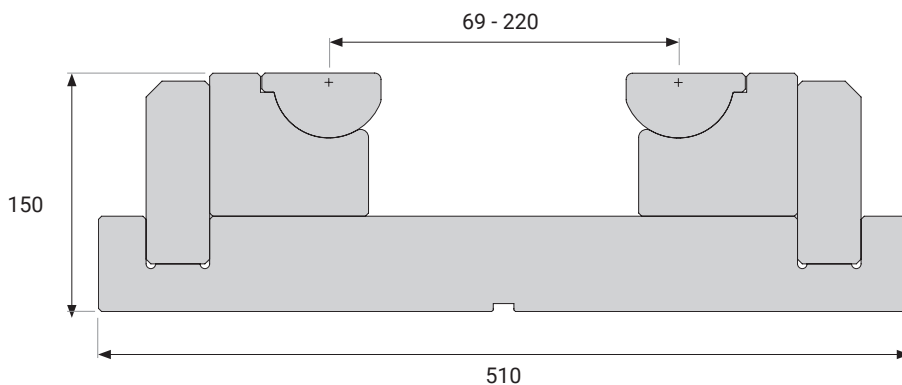

RVHD4

500mm	200.0 kg (441lbs)
250mm	100.0 kg (220lbs)

Maximum recommended thickness
30mm (1.181")

Modular CNC Controlled Rolla-V

The world's first Modular CNC Controlled, Pneumatic Rolla-V Press Brake Tooling Die, change the "V" size from 55mm wide up to 142mm with a touch of one button.

Bend up to 20mm material.

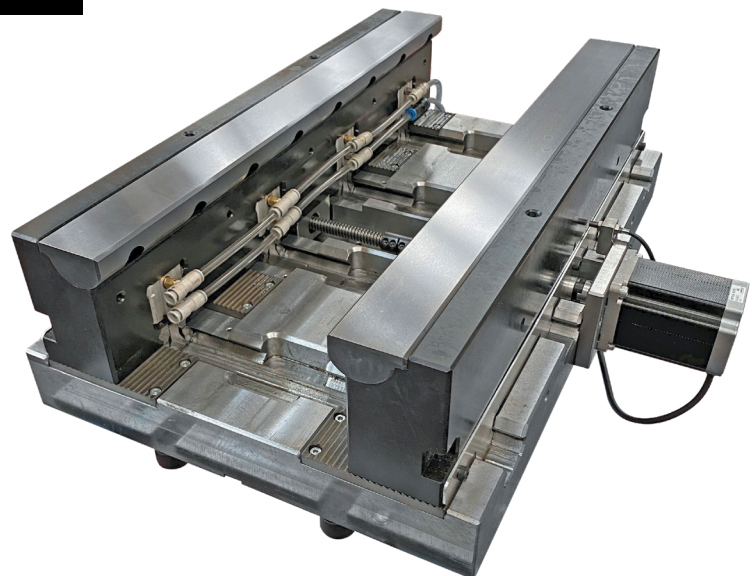

FAB SUPPLY

INCORPORATED

This catalog illustrates our standard range of Rolla-V products.

If you do not see the product that you require, we can work together for a solution based on your specifications and needs.

Please call to discuss your individual requirements.

Call Us Today!

630.691.8665

Toll Free: 866.322.8665

Fax: 630.691.8667

Email: Sales@fabsupplyinc.com

WWW.FABSUPPLYINC.COM

About the company: Fab Supply is an ISO 9001 certified, full-service provider of press brake tooling and accessories. Products include precision ground tooling for all Trumpf, Bystronic, LVD and Amada Machines, Rolla-V, conventional tooling, adjustable press brake dies, tooling cabinets and safety products.

Fab Supply Inc.

2000 Bloomingdale Road, Unit 220

Glendale Heights IL 60139