

# EURAM

## WORLD WIDE EURAM

**FAB  
SUPPLY**  
INCORPORATED

TOLL FREE: 866-322-8665  
OFFICE: 630-691-8665  
FAX: 630-691-8667  
Addison, Illinois 60101  
[www.FabSupplyInc.com](http://www.FabSupplyInc.com)

COMPANY WITH QUALITY MANAGEMENT  
SYSTEM CERTIFIED BY DNV  
= ISO 9001:2008 =

UTENSILI AD ALTA PRECISIONE  
PER PRESSE PIEGATRICI  
HIGH PRECISION PRESS BRAKE TOOLS  
PRÄZISIONS ABKANTWERKZEUGE  
OUTILS DE PLIAGE HAUTE PRECISION

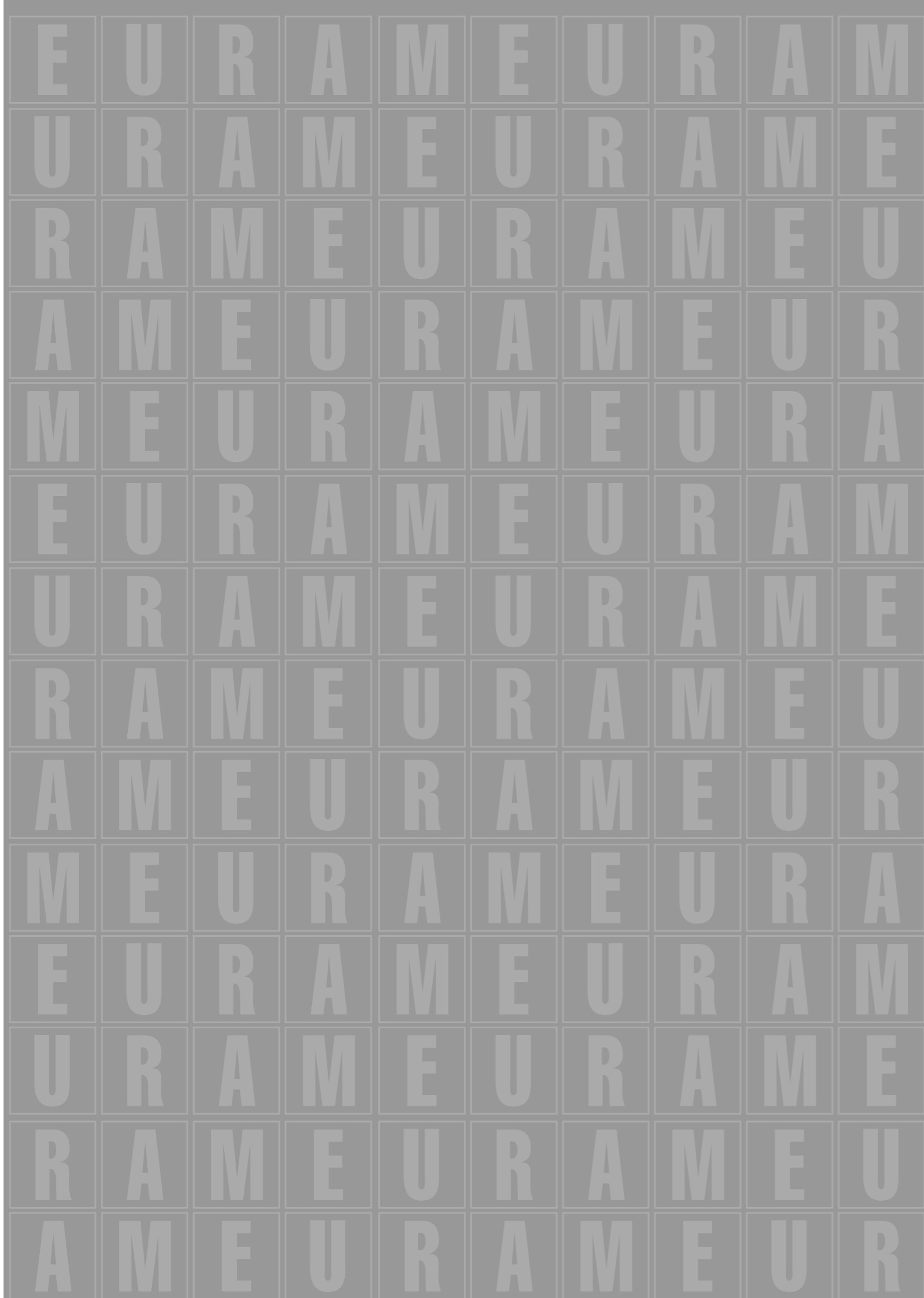

**E U R A M**

WORLD WIDE EURAM

---

[www.euram.it](http://www.euram.it)



**EURAM**  
WORLD WIDE EURAM



## INDICE / INDEX

CHI SIAMO COMPANY	P. 06
PUNZONI PUNCHES	P. 09
GRAFICI DEI LIMITI DI PIEGATURA BEND LIMIT GRAPHICS	P. 26
MATRICI DIES	P. 42
UTENSILI PIEGA-SCHIACCIA HEMMING TOOLING	P. 66
PIEGA-SCHIACCIA PNEUMATICI PNEUMATIC HEMMING TOOLING	P. 68
SUPPORTI MATRICI LOWER TOOL HOLDERS	P. 76
INTERMEDIARI SUPPORTO PUNZONI INTERMEDIATE UPPER TOOL HOLDERS	P. 86
STAFFA DI SICUREZZA SECURITY CLAMP	P. 90
INTERMEDI PNEUMATICI PNEUMATIC INTERMEDIATES	P. 92
MONTAGGIO INTERMEDI PNEUMATICI PNEUMATIC INTERMEDIATES ASSEMBLY	P. 93
PUNZONI TIPO WILA / TRUMPF UPPER TOOLS WILA / TRUMPF SYSTEM	P. 100
MATRICI TIPO WILA / TRUMPF LOWER TOOLS WILA / TRUMPF SYSTEM	P. 102
UTENSILI SPECIALI SPECIAL TOOLS	P. 105
TABELLA DI PIEGATURA BENDING TABLE	P. 107



## SIMBOLI / SYMBOLS

24h

**Spedizione tassativa entro le 24H per tutti gli articoli con questo logo.**

Delivery within 24 hours for all items with this logo - J.I.T.(Just In Time) service.

Alle Artikel mit diesem Symbol führen wir ab Lager! 24-Std.-Lieferservice.

Expédition formelle dans les 24 heures pour toutes les articles avec ce label.

6w

**Spedizione entro le 6 settimane per tutti gli articoli con questo logo.**

Delivery within 6 weeks for all items with this logo.

Alle Artikel mit diesem Symbol führen wir ab Lager! 6-W-Lieferservice.

Expédition dans les 6 semaines pour toutes les articles avec ce label.



Mat.: acciaio C 45 (50-55 HRC)  
Mat.: CK 45 (50-55 HRC)



Mat.: acciaio C 55 (53-60 hrc)  
Mat.: CK 55 (53-60 hrc)



Mat.: UNI EN 10083/1 - ISO 683 - (42CrM04) - (53-60 HRC)

Mat.: UNI EN 10083/1 - ISO 683 - (42CrM04) - (53-60 HRC)

## CHI SIAMO

I nostri 25 anni di esperienza sul mercato mondiale, operati al più alto livello, hanno fatto di EURAM una delle aziende leader della piegatura della lamiera.

Oggi EURAM è in grado di fornire utensili intercambiabili tali da soddisfare tutte le esigenze del cliente fino ad una tolleranza critica di +/- 0.005 millimetri.



UMBERTO L. COELLI - President & C.E.O.



## COMPANY

Our 25 years of experience on the worldwide market, operating at the highest level, has made Euram one of the leading companies in the sheet metal bending sector.

Today we are able to supply interchangeable tools and can satisfy all customer requirements up to a critical tolerance of +/- 0.005 mm.

## GESELLSCHAFT

Unsere 25 Jahren Erfahrung auf dem Weltmarkt, in denen wir auf höchstem Niveau operieren, haben Euram zu einer der führenden Gesellschaften im Bereich des Biegens von Metallblechen gemacht. Heute sind wir in der Lage, austauschbare Werkzeuge zu liefern und können alle Kundenwünsche mit einer Toleranzgrenze von +/- 0.005 mm erfüllen.

## SOCIÉTÉ

Notre expérience de 25 ans sur le marché international, agissant au plus haut niveau, a fait d'Euram l'une des entreprises leader dans le secteur du pliage de tôle. Aujourd'hui, nous sommes en mesure de fournir des outils interchangeables et de satisfaire toutes les exigences de nos clients jusqu'au niveau critique de tolérance de +/- 0.005 mm.



Gli investimenti finanziari effettuati nel corso degli ultimi anni e la collaborazione con un'azienda leader nel settore della produzione e lo sviluppo di rettifiche CNC ci hanno permesso di rinnovare completamente la struttura tecnologica nei diversi impianti di produzione in tutta Italia ed in Europa.

Unsere technologischen und finanziellen Investitionen der vergangenen Jahre und die Zusammenarbeit mit führenden Hersteller - und Entwicklungsfirmen von CNC-Schleifmaschinen haben es uns erlaubt, unseren Werkzeugmaschinenpark in unseren verschiedenen Produktionsstätten in Italien und Europa vollständig zu erneuern.

Our technological and financial investments over the past few years and the cooperation with leading companies in the production and development of CNC grinding machines have allowed us to completely renew our machine tools in our various manufacturing facilities throughout Italy and Europe.

Nos investissements technologiques et financiers de ces dernières années et notre coopération avec les compagnies leader dans la production et le développement d'affûteuses CNC nous ont permis de renouveler intégralement nos machines-outils dans nos différentes usines de production situées à travers toute l'Italie et l'Europe.

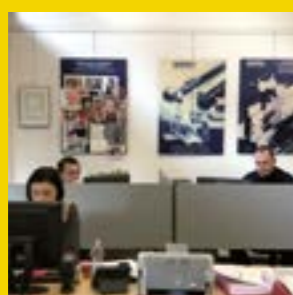

DOVE SIAMO - WHERE WE ARE  
WO WIR SIND - OU NOUS SOMMES

**EURAM Italiana srl**

Head Office:

Traversante San Leonardo, 13/A, 43122 PARMA (Italy)

Ph: +39 0521 776545 - Fax: +39 0521 776353

e-mail: [euram@euram.it](mailto:euram@euram.it) - internet: [www.euram.it](http://www.euram.it)



Utensili per presse piegatrici realizzati con standards di qualità superiore, temprati a induzione sulle parti di lavoro e totalmente rettificati. Lunghezza standard: 835mm; 414 mm; 835 frazionati.

Press Brake Tooling in best quality, induction hardened and ground on the working surfaces. Standard lenght: 835mm; 415 mm; 835 sectioned.

Abkantwerkzeuge in bester qualität, induktionsgehärtet - arbeitsflächen geschliffen. Standardlängen: 835mm; 415 mm; 835 sektioniert.

Outils de pliage de qualité supérieure tempérés par induction avec faces principales rectifiées. Longueur standard: 835mm; 415 mm; 835 fractionné.

## PUNZONI PUNCHES



Utensili per presse piegatrici realizzati con standards di qualità superiore, temprati a induzione sulle parti di lavoro e totalmente rettificati. Lunghezza standard: 835mm; 414 mm; 835 frazionati.

Press Brake Tooling in best quality, induction hardened and ground on the working surfaces. Standard length: 835mm; 415 mm; 835 sectioned.

Abkantwerkzeuge in bester Qualität, induktionsgehärtet - arbeitsflächen geschliffen. Standardlängen: 835mm; 415 mm; 835 sektioniert.

Outils de pliage de qualité supérieure trempés par induction avec faces principales rectifiées. Longueur standard: 835mm; 415 mm; 835 fractionné.

1010 / A / 88°	
R= 0.2 mm	H= 66.90
R= 0.8 mm	H= 66.60
R= 1.5 mm	H= 65.90
R= 2.3 mm	H= 65.60
R= 3 mm	H= 65.25
SOLID 100 T/m	★

24H

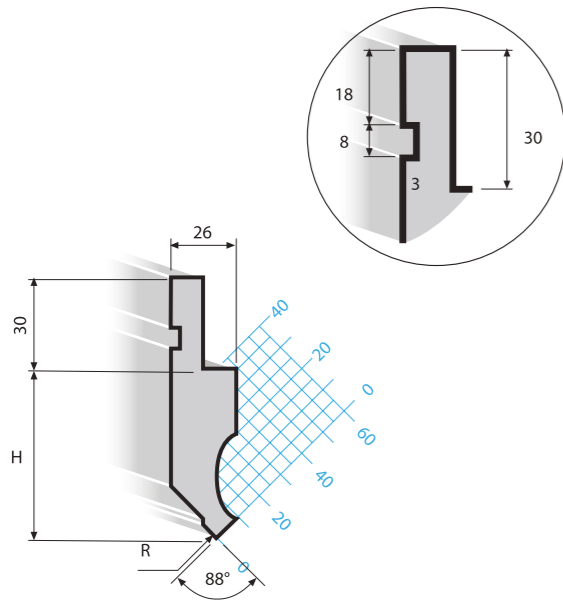

1010 / A / 88° / 0.8 / 105	
SOLID 100 T/m	★

24H

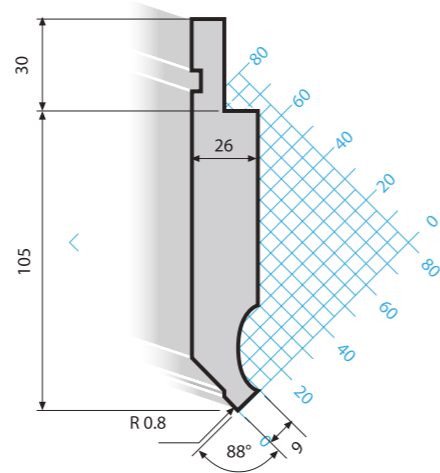

1010 / A / 75° / 0.8	
SOLID 100 T/m	★

24H

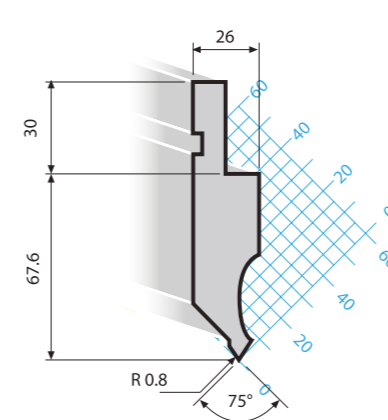

1010 / A / 75° / 0.8 / 105	
SOLID 100 T/m	★

24H

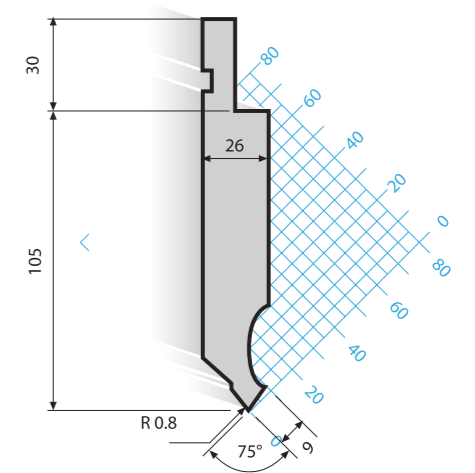

1010 / A / 85° / 0.8	
SOLID 100 T/m	★

24H

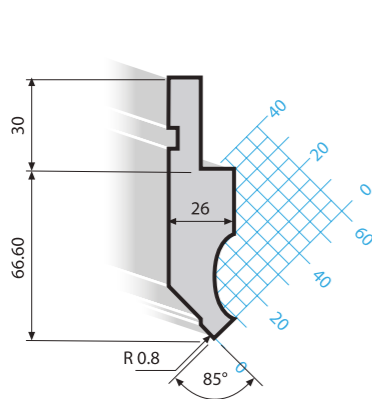

1010 / A / 85° / 0.8 / 105	
SOLID 100 T/m	★

24H

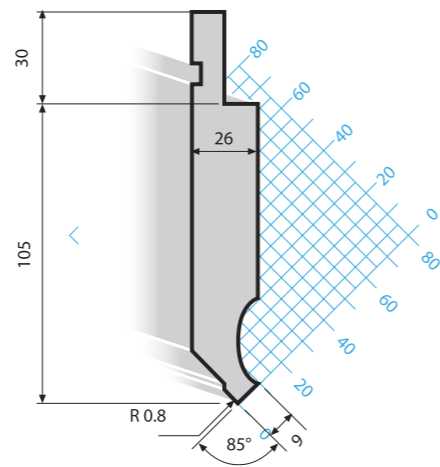

1010 / A / 90°	
R= 0.2 mm	H= 66.9
R= 0.8 mm	H= 66.6
SOLID 100 T/m	★

24H

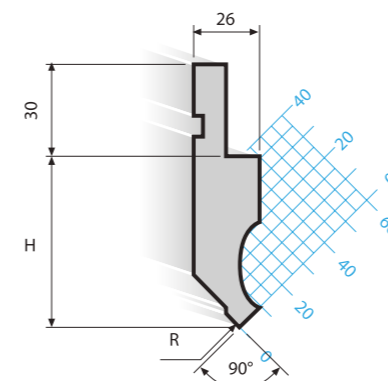

1010 / 88°	
PHASE	
0.8 mm	H= 66.1
2.9 mm	H= 65
SOLID 100 T/m	★

24H

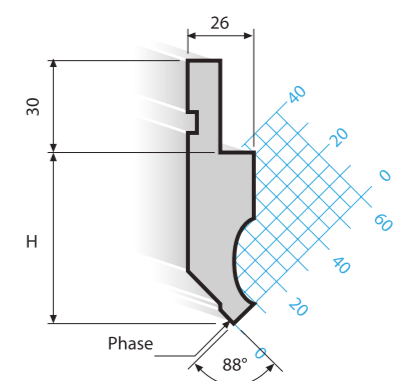

Utensili per presse piegatrici realizzati con standards di qualità superiore, temprati a induzione sulle parti di lavoro e totalmente rettificati. Lunghezza standard: 835mm; 414 mm; 835 frazionati.

Press Brake Tooling in best quality, induction hardened and ground on the working surfaces. Standard lenght: 835mm; 415 mm; 835 sectioned.

Abkantwerkzeuge in bester Qualität, induktionsgehärtet - arbeitsflächen geschliffen. Standardlängen: 835mm; 415 mm; 835 sektioniert.

Outils de pliage de qualité supérieure trempés par induction avec faces principales rectifiées. Longueur standard: 835mm; 415 mm; 835 fractionné.

1010 / 90° / 0.8

24H

SOLID 100 T/m

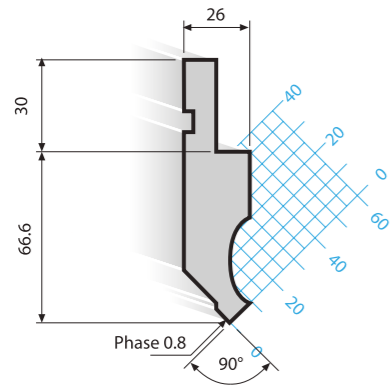

1011 / 45°

24H

PHASE

0.8 mm | H= 66.03

1.5 mm | H= 65.20

SOLID 70 T/m

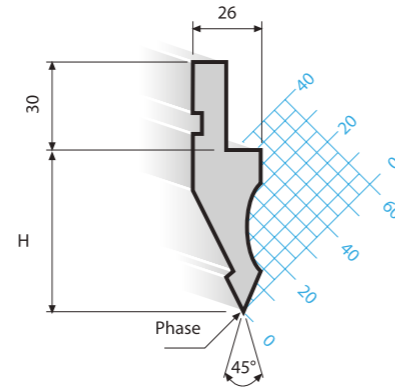

1012 / 35° / 1

24H

SOLID 70 T/m

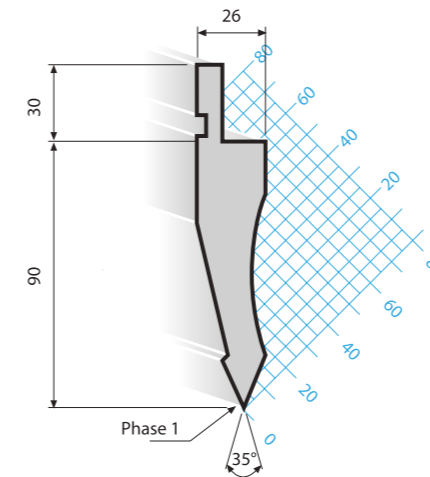

1012 / A / 35° / 1

24H

SOLID 70 T/m

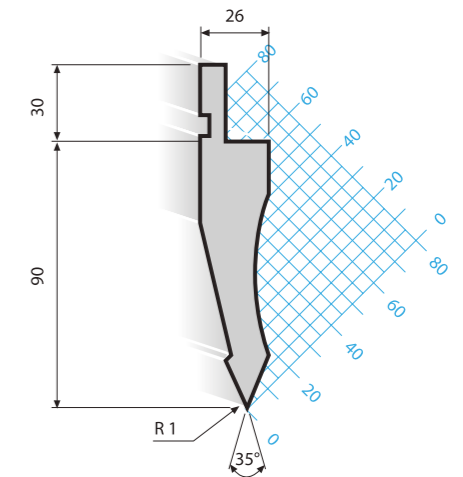

1011 / A / 45°

24H

R= 0.4 mm | H= 66.40

R= 0.8 mm | H= 66.03

R= 1.5 mm | H= 65.20

SOLID 70 T/m

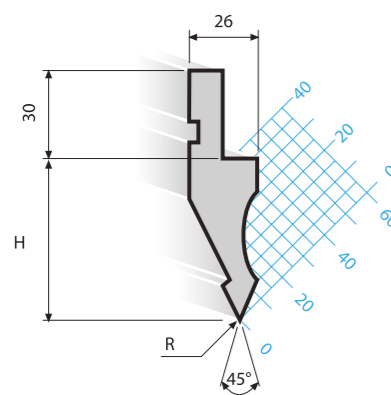

3864 / 35° / 1

24H

SOLID 50 T/m

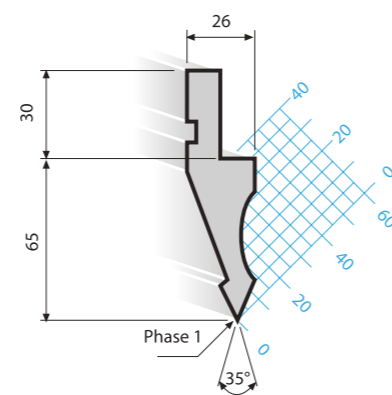

1013

24H

R= 5 mm | 35°

R= 6 mm | 60°

R= 6 mm | 80°

SOLID 100 T/m

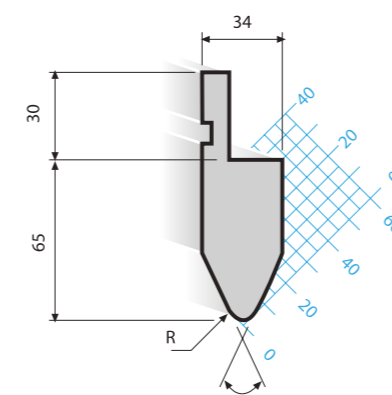

1014 / A / 75° / 0.8

24H

SOLID 50 T/m

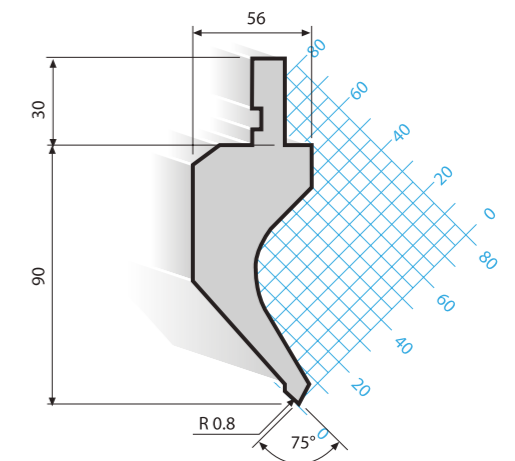



Utensili per presse piegatrici realizzati con standards di qualità superiore, temprati a induzione sulle parti di lavoro e totalmente rettificati. Lunghezza standard: 835mm; 414 mm; 835 frazionati.

Press Brake Tooling in best quality, induction hardened and ground on the working surfaces. Standard lenght: 835mm; 415 mm; 835 sectioned.

Abkantwerkzeuge in bester Qualität, induktionsgehärtet - arbeitsflächen geschliffen. Standardlängen: 835mm; 415 mm; 835 sektioniert.

Outils de pliage de qualité supérieure trempés par induction avec faces principales rectifiées. Longueur standard: 835mm; 415 mm; 835 fractionné.

**1014 / 88°** **24H**

PHASE	
0.8 mm	H= 89.59
2.9 mm	H= 88.50
SOLID 50 T/m	★

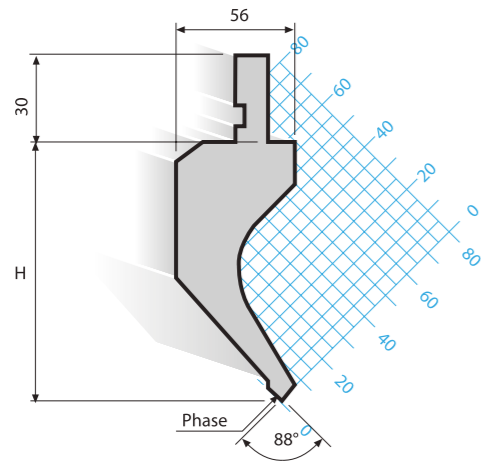

**1014 / A / 88°** **24H**

R= 0.2 mm	H= 89.91
R= 0.8 mm	H= 89.65
R= 3 mm	H= 88.68
SOLID 50 T/m	★

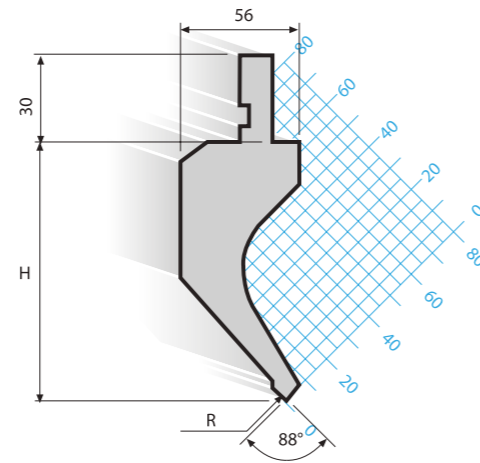

**1014 / A / 88° / 0.8 / 6** **24H**

SOLID 50 T/m ★

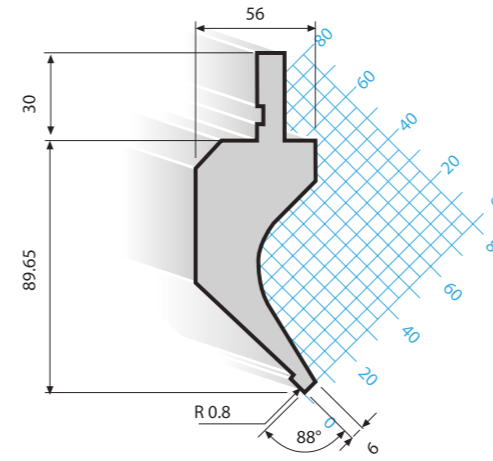

**1014 / 90° / 0.8** **24H**

SOLID 50 T/m ★

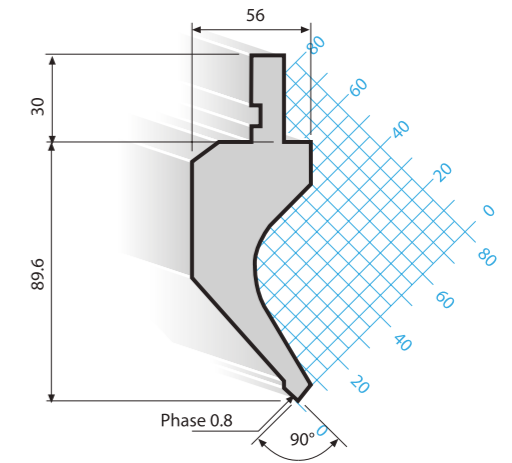

**1014 / A / 85° / 0.8** **24H**

SOLID 50 T/m ★

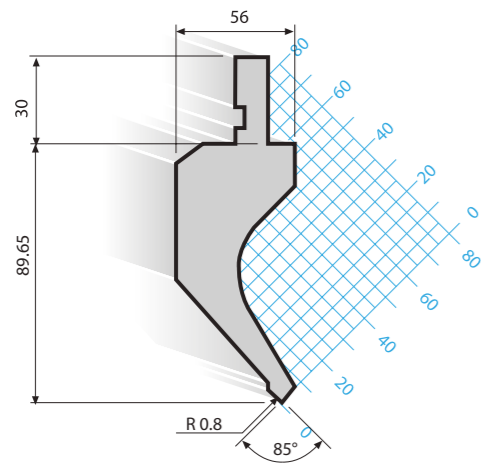

**1014 / 88° / 0.8 / 6** **24H**

SOLID 50 T/m ★

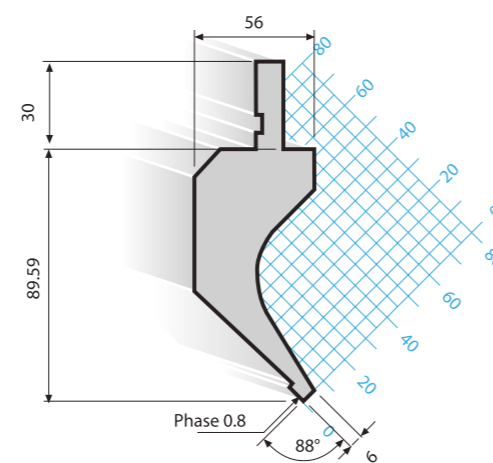

**1015 / A / 88°** **24H**

R= 0.2 mm	H= 104.9
R= 0.8 mm	H= 104.6
R= 1.5 mm	H= 103.9
SOLID 50 T/m	★

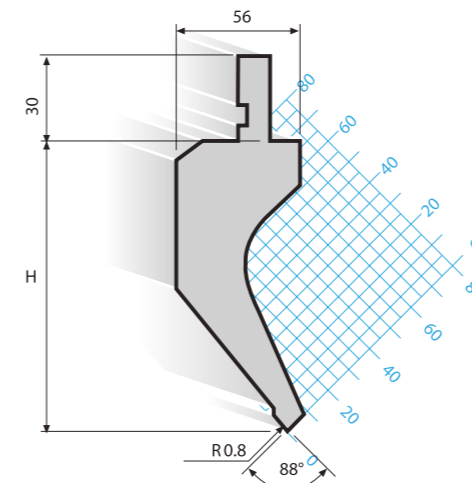

**1015 / A / 85° / 0.8** **24H**

SOLID 50 T/m ★

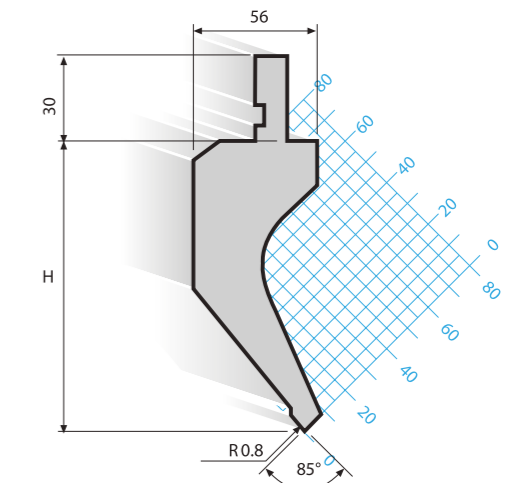

Utensili per presse piegatrici realizzati con standards di qualità superiore, temprati a induzione sulle parti di lavoro e totalmente rettificati. Lunghezza standard: 835mm; 414 mm; 835 frazionati.

Press Brake Tooling in best quality, induction hardened and ground on the working surfaces. Standard length: 835mm; 415 mm; 835 sectioned.

Abkantwerkzeuge in bester Qualität, induktionsgehärtet - arbeitsflächen geschliffen. Standardlängen: 835mm; 415 mm; 835 sektioniert.

Outils de pliage de qualité supérieure trempés par induction avec faces principales rectifiées. Longueur standard: 835mm; 415 mm; 835 fractionné.

1015 / 88°

24H

PHASE	
1 mm	H= 104.48
3 mm	H= 103.45
SOLID 50 T/m	★

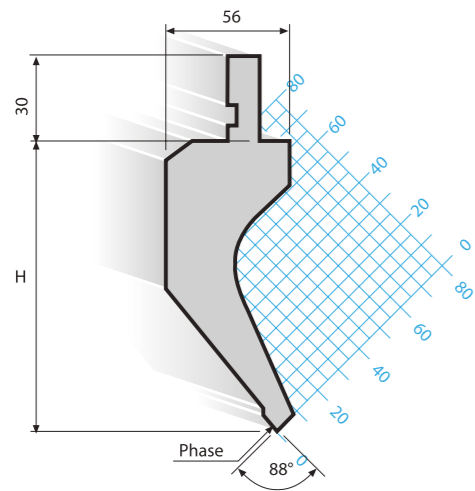

1015 / 90° / 1

24H

SOLID 50 T/m ★

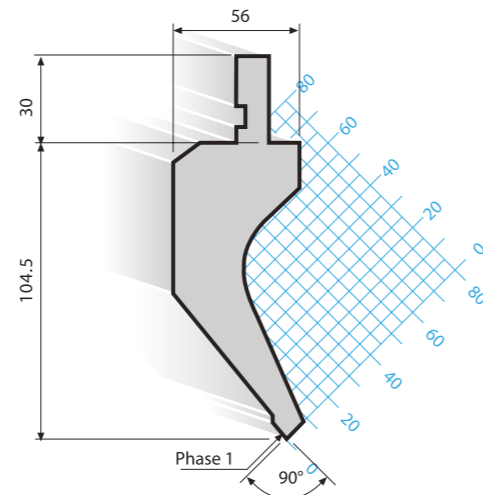

1017 / A / 30° / 0.8 / W

24H

SOLID 40 T/m ★

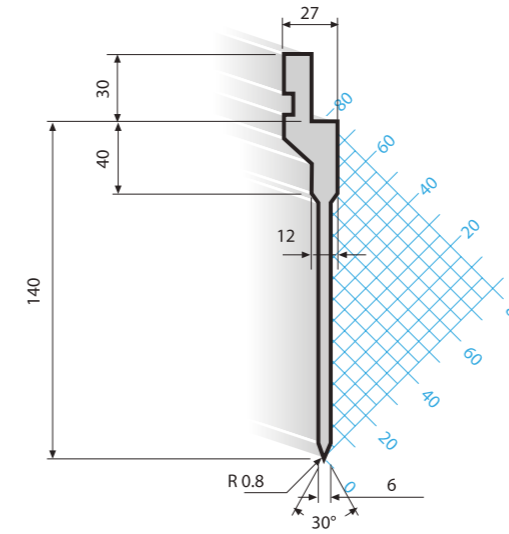

1017 / 35° / 0.8

24H

SOLID 50 T/m ★

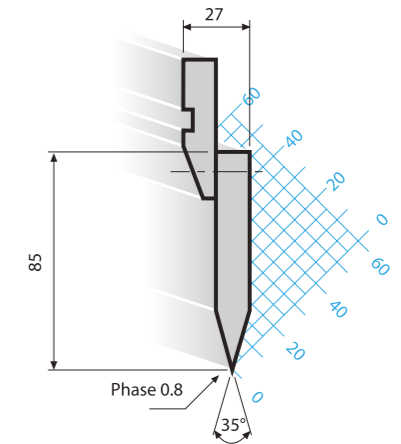

1016 / α / 0.6

24H

α= 88°	
α= 90°	
SOLID 15 T/m	★

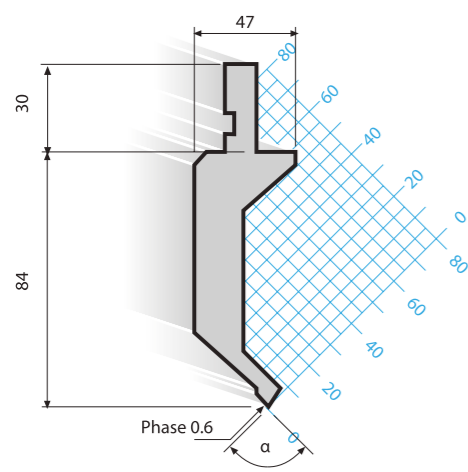

1017 / 26° / 0.8

24H

SOLID 100 T/m ★

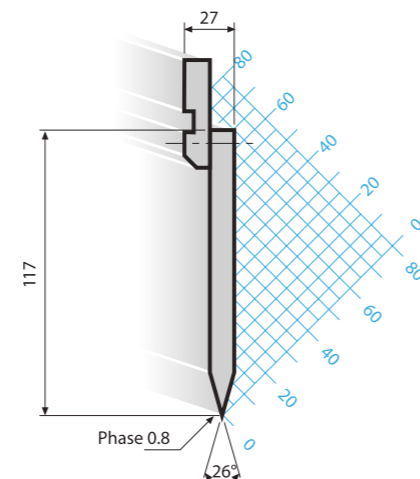

1018 / 60° / 0.8

24H

SOLID 70 T/m ★

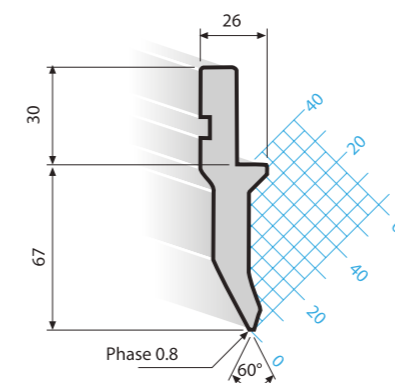

1019 / A / 88°

24H

R= 0.8 mm	
R= 3 mm	
SOLID 50 T/m	★

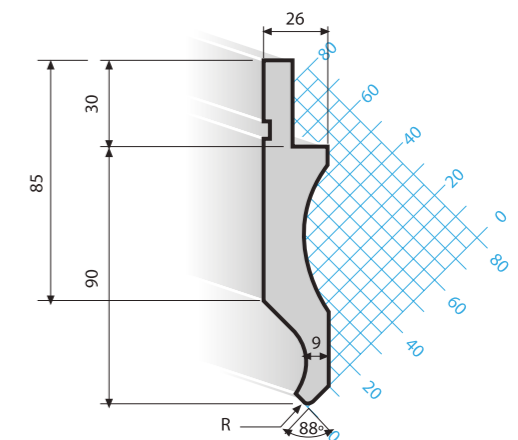

Utensili per presse piegatrici realizzati con standards di qualità superiore, temprati a induzione sulle parti di lavoro e totalmente rettificati. Lunghezza standard: 835mm; 414 mm; 835 frazionati.

Press Brake Tooling in best quality, induction hardened and ground on the working surfaces. Standard length: 835mm; 415 mm; 835 sectioned.

Abkantwerkzeuge in bester Qualität, induktionsgehärtet - arbeitsflächen geschliffen. Standardlängen: 835mm; 415 mm; 835 sektioniert.

Outils de pliage de qualité supérieure trempés par induction avec faces principales rectifiées. Longueur standard: 835mm; 415 mm; 835 fractionné.

1020 / A / 75° / 0.8

24H

SOLID 50 T/m

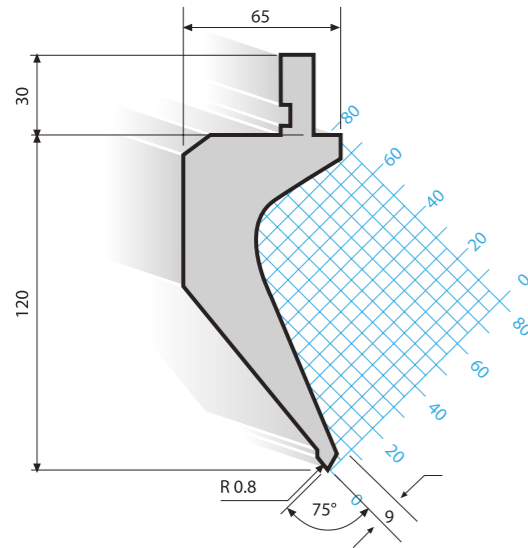

1020 / A / 88° / 0.2

24H

SOLID 50 T/m

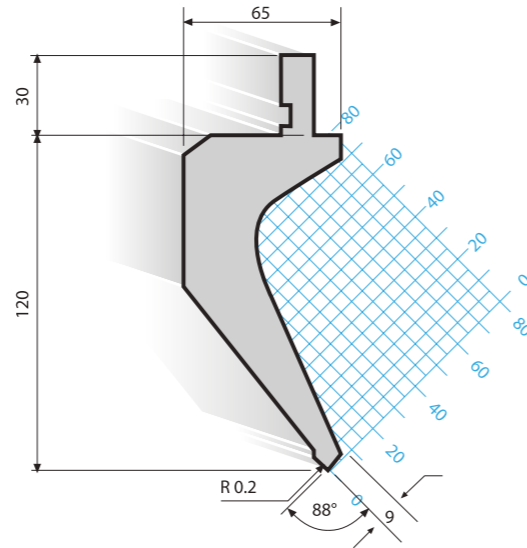

1022 / A / 88° / 0.2

24H

SOLID 50 T/m

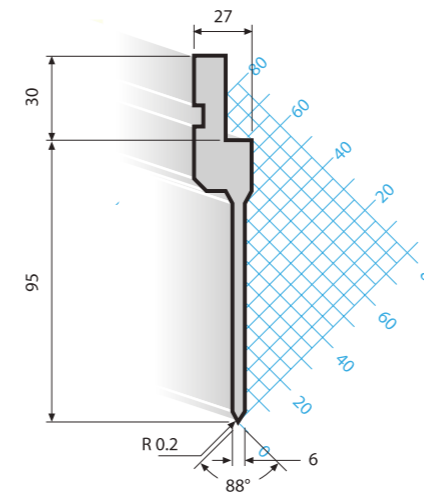

1023 / A / 88° / 0.2

24H

SOLID 50 T/m

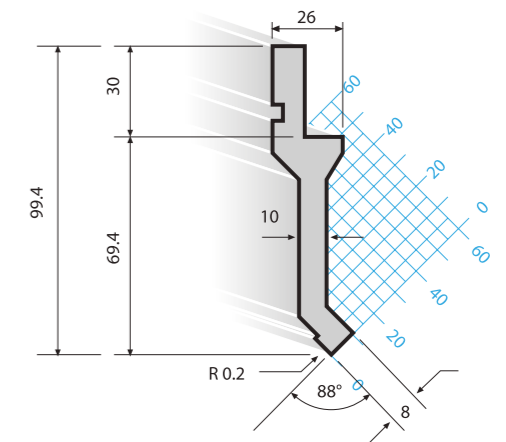

1021 / A / 30° / 0.8

24H

SOLID 100 T/m

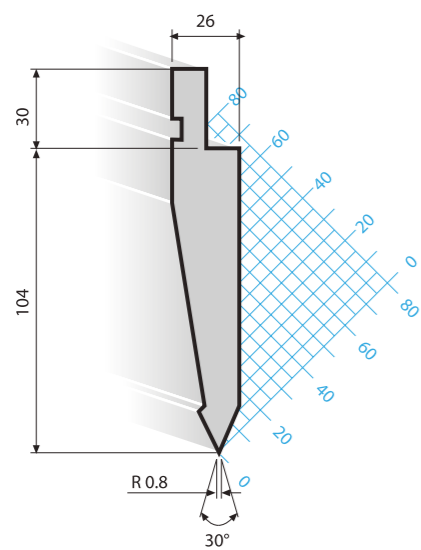

1022 / A / 75° / 0.8

24H

SOLID 50 T/m

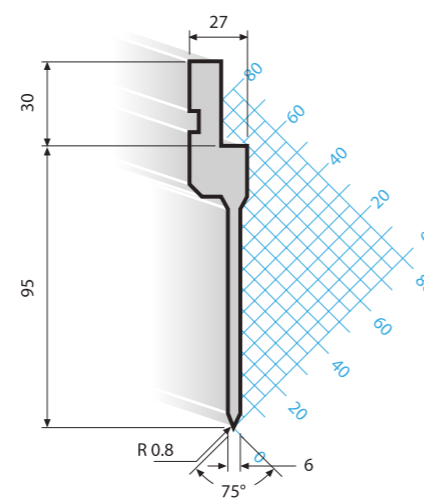

1023 / A / 90° / 0.2

24H

SOLID 50 T/m

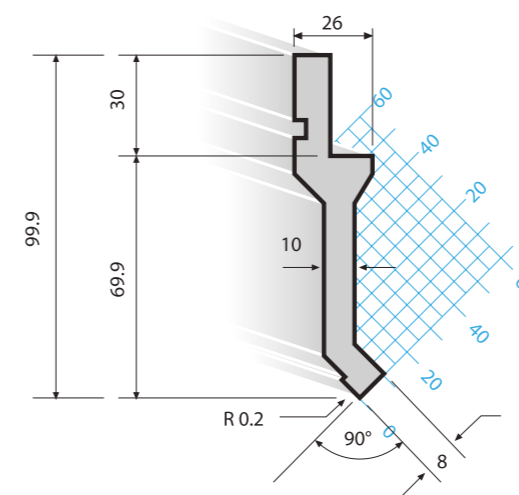

1024 / A / 88° / 0.2

24H

SOLID 50 T/m

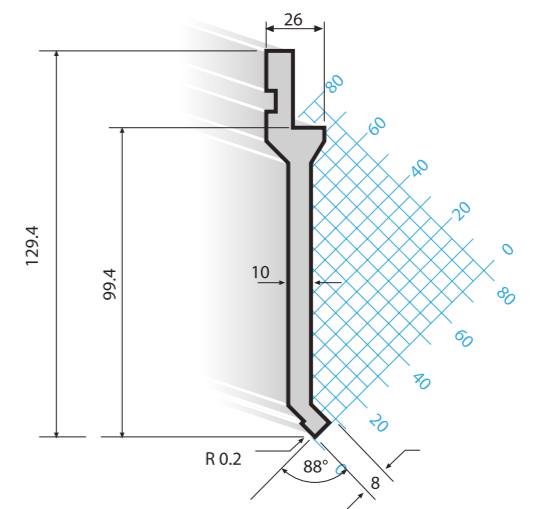

Utensili per presse piegatrici realizzati con standards di qualità superiore, temprati a induzione sulle parti di lavoro e totalmente rettificati. Lunghezza standard: 835mm; 414 mm; 835 frazionati.

Press Brake Tooling in best quality, induction hardened and ground on the working surfaces. Standard length: 835mm; 415 mm; 835 sectioned.

Abkantwerkzeuge in bester Qualität, induktionsgehärtet - arbeitsflächen geschliffen. Standardlängen: 835mm; 415 mm; 835 sektioniert.

Outils de pliage de qualité supérieure trempés par induction avec faces principales rectifiées. Longueur standard: 835mm; 415 mm; 835 fractionné.

1024 / A / 85° / 0.2

24H

SOLID 50 T/m ★

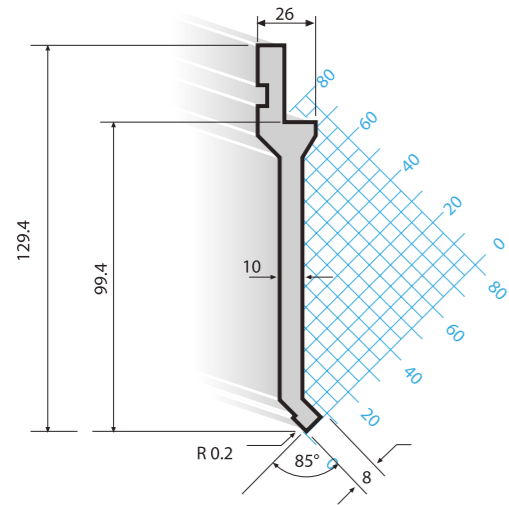

1025 / A / 88° / 0.2

24H

SOLID 40 T/m ★

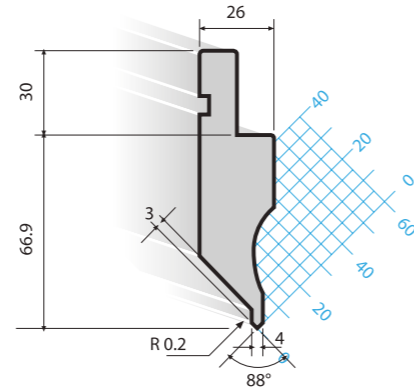

1028 / A / 88° / 0.8

24H

SOLID 80 T/m ★

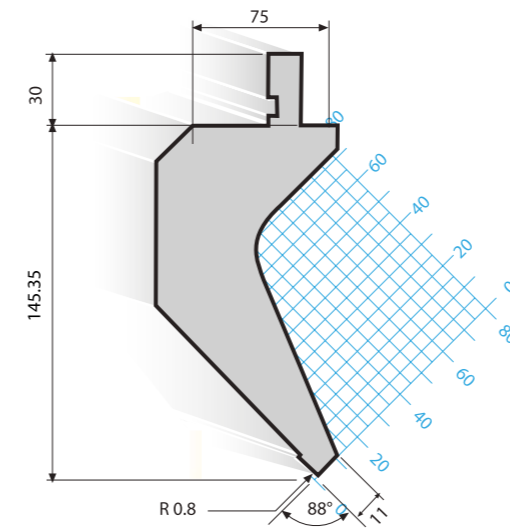

1029 / A / 85°

24H

R= 5 mm H= 105  
R= 6.5 mm H= 104.03

SOLID 70 T/m ★

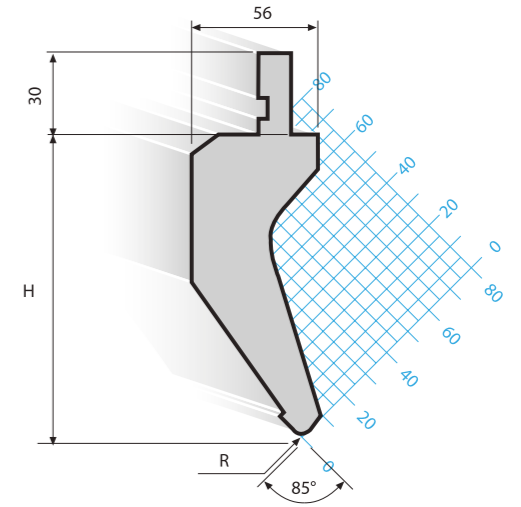

1026 / α / 0.2

24H

α= 90°

α= 88°

SOLID 20 T/m ★

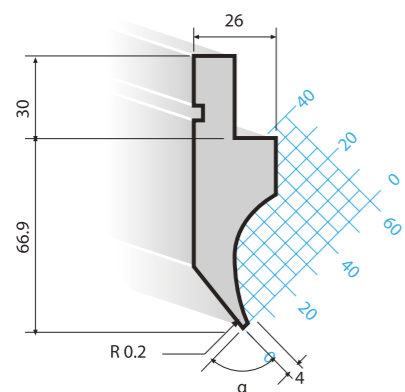

1027 / A / 30° / 0.8

24H

SOLID 70 T/m ★

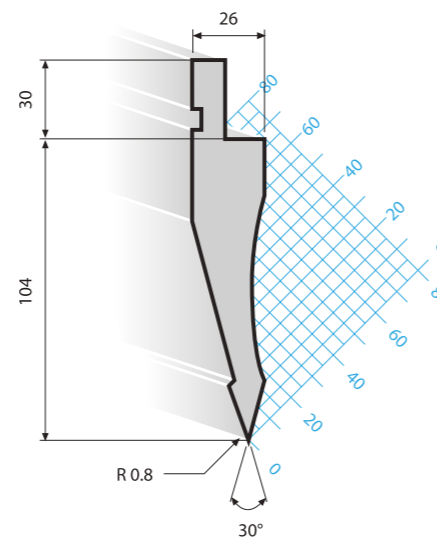

1030 / A / 88° / 0.8

24H

SOLID 60 T/m ★

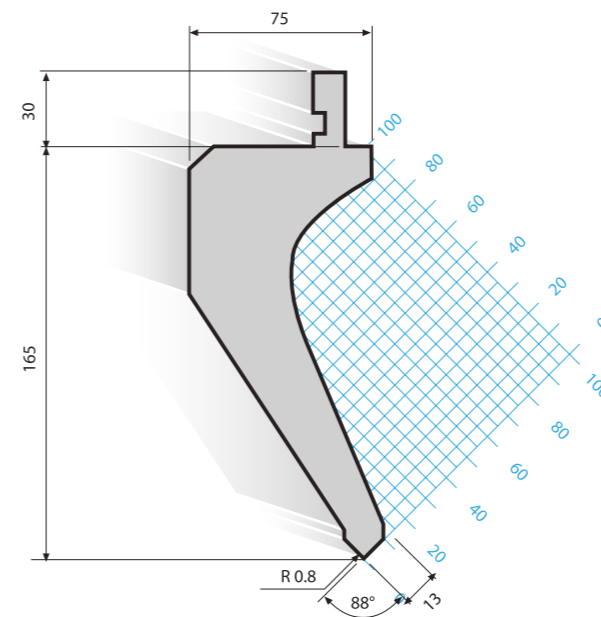

1031 / A / 60° / 0.8

24H

SOLID 60 T/m ★

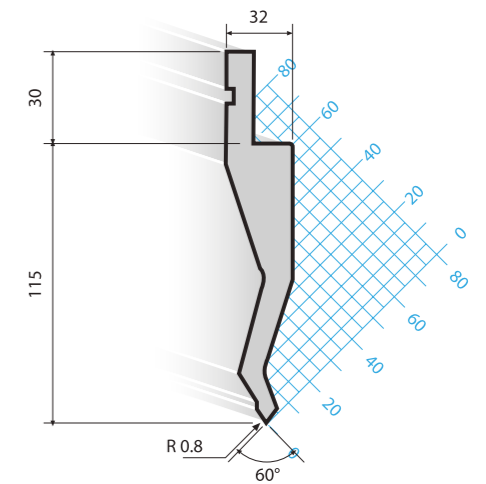

Utensili per presse piegatrici realizzati con standards di qualità superiore, temprati a induzione sulle parti di lavoro e totalmente rettificati. Lunghezza standard: 835mm; 414 mm; 835 frazionati.

Press Brake Tooling in best quality, induction hardened and ground on the working surfaces. Standard length: 835mm; 415 mm; 835 sectioned.

Abkantwerkzeuge in bester Qualität, induktionsgehärtet - arbeitsflächen geschliffen. Standardlängen: 835mm; 415 mm; 835 sektioniert.

Outils de pliage de qualité supérieure trempés par induction avec faces principales rectifiées. Longueur standard: 835mm; 415 mm; 835 fractionné.

**1032 / A / 88° / 0.8**

**24H**

SOLID 45 T/m ★

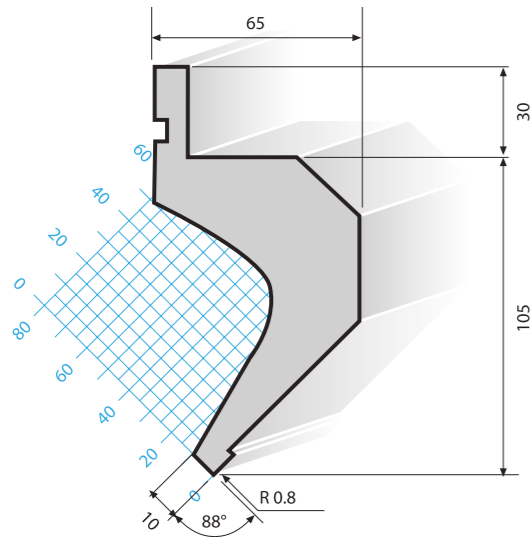

**1033 / A / 28° / 0.6**

**24H**

B= 8 mm  
B= 10 mm  
B= 12 mm  
SOLID 70 T/m ★

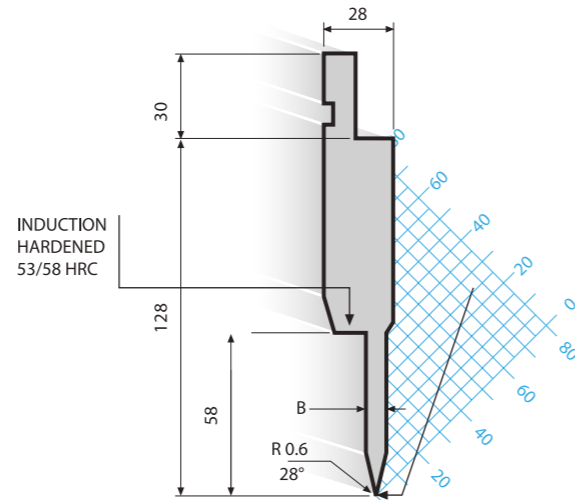

**1036 / A / 60° / 0.8**

**24H**

SOLID 70 T/m ★★

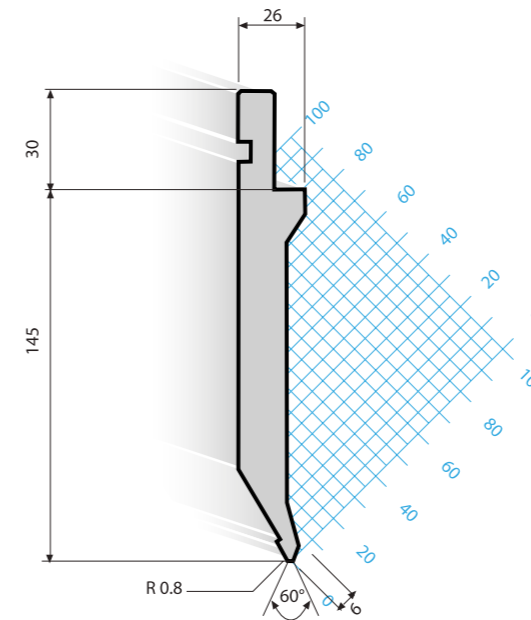

**1037 / A / 60° / 2**

**24H**

SOLID 100 T/m ★★

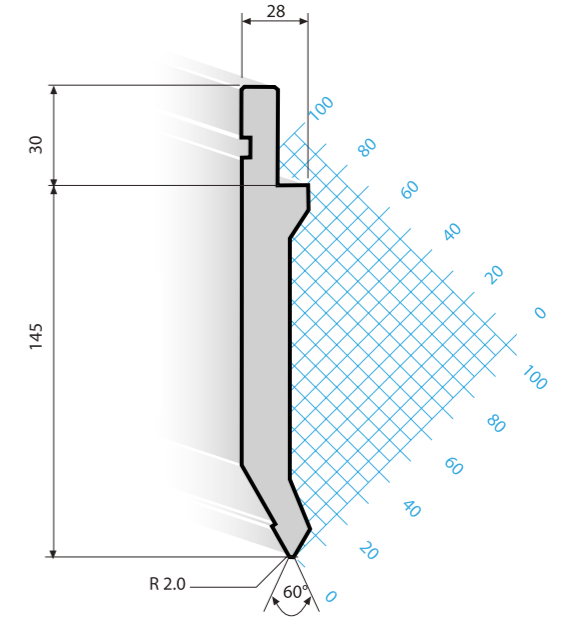

**1034 / A / 85° / 2**

**24H**

SOLID 90 T/m ★★

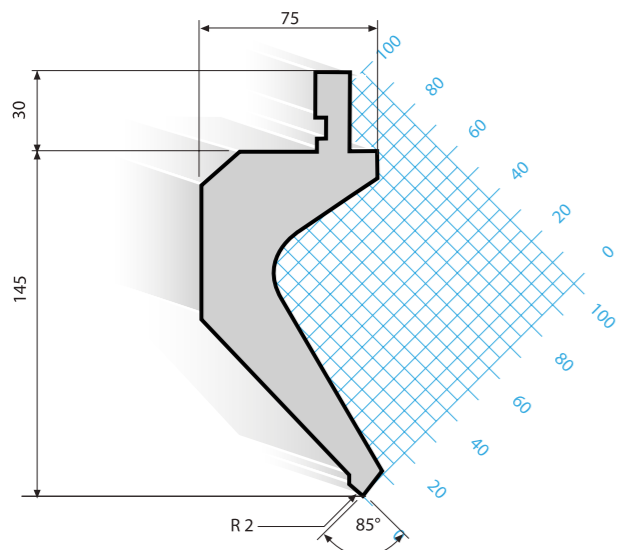

**1035 / A / 85° / 1.25**

**24H**

SOLID 90 T/m ★★

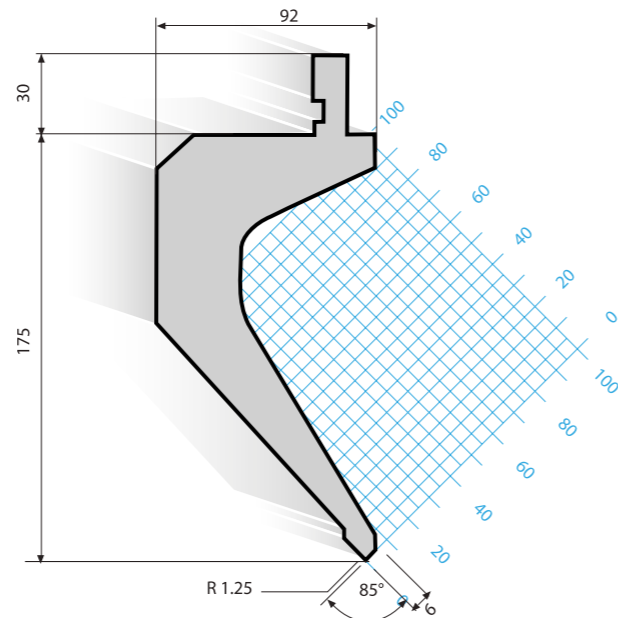

**1038 / A / 26° / 0.8**

**24H**

SOLID 100 T/m ★★

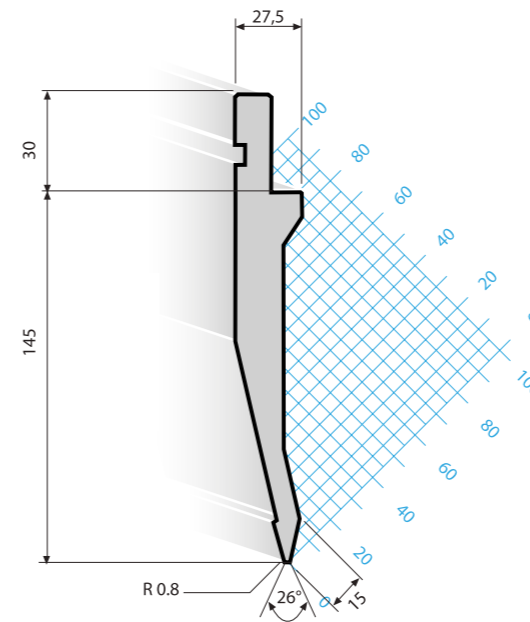

**1039 / A / 26° / 1.5**

**24H**

SOLID 100 T/m ★★

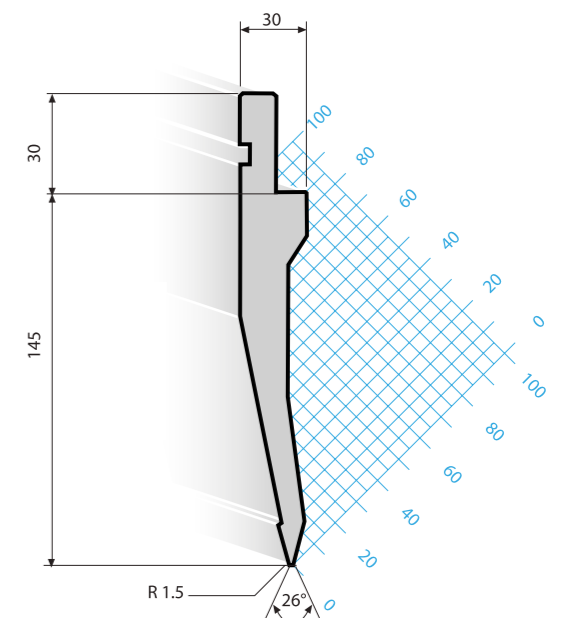

Utensili per presse piegatrici realizzati con standards di qualità superiore, temprati a induzione sulle parti di lavoro e totalmente rettificati. Lunghezza standard: 835mm; 414 mm; 835 frazionati.

Press Brake Tooling in best quality, induction hardened and ground on the working surfaces. Standard length: 835mm; 415 mm; 835 sectioned.

Abkantwerkzeuge in bester Qualität, induktionsgehärtet - arbeitsflächen geschliffen. Standardlängen: 835mm; 415 mm; 835 sektioniert.

Outils de pliage de qualité supérieure trempés par induction avec faces principales rectifiées. Longueur standard: 835mm; 415 mm; 835 fractionné.

4003

6w

SOLID 50 T/m ★

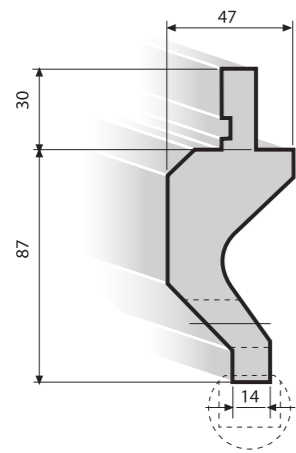

4004

6w

SOLID 50 T/m ★

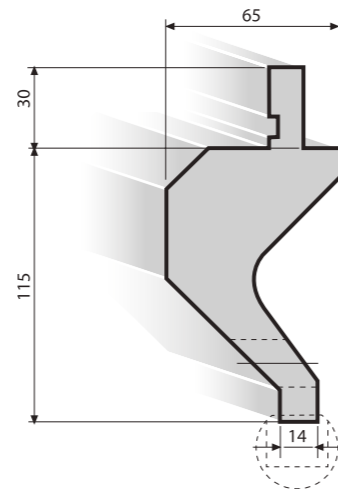

4002

24H

SOLID 100 T/m ★

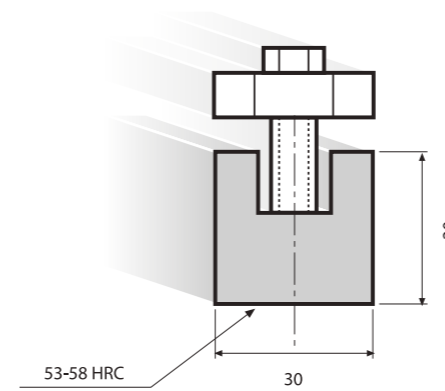

4009 / R

24H

- R= 7,5 mm
- R= 10 mm
- R= 12,5 mm
- R= 15 mm
- R= 17,5 mm
- R= 20 mm
- R= 25 mm
- R= 30 mm
- R= 40 mm
- R= 50 mm

SOLID 100 T/m ★

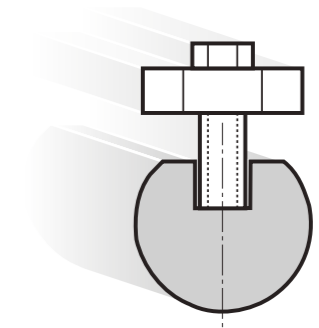

4005

24H

H= 67 | H= 105

SOLID 100 T/m ★

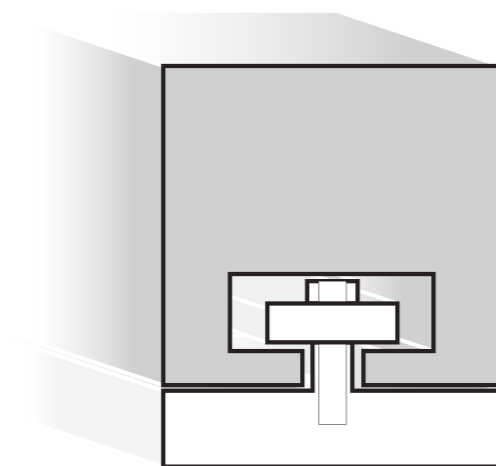
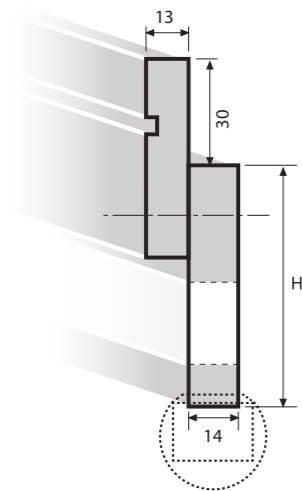

Frazionatura standard per 835 mm - Standard sectioning for 835 mm  
Standard Sektionierung für 835 mm - Fractionnement standard pour 835 mm



GRAFICO DEL LIMITE DI PIEGATURA / BEND LIMIT GRAPHIC

1010 - 1010 / A

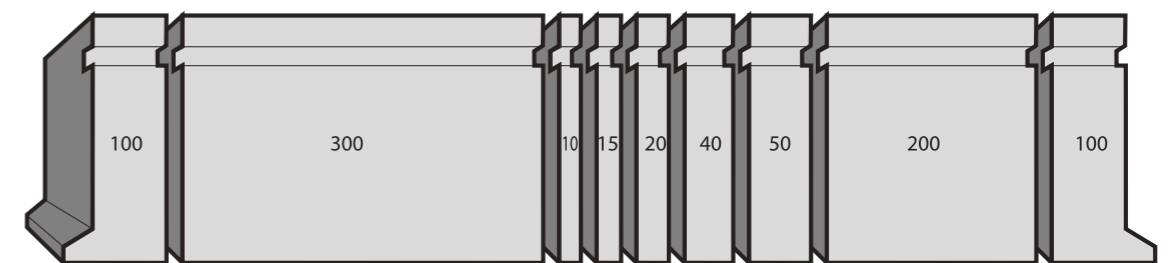

GRAFICO DEL LIMITE DI PIEGATURA / BEND LIMIT GRAPHIC

1026

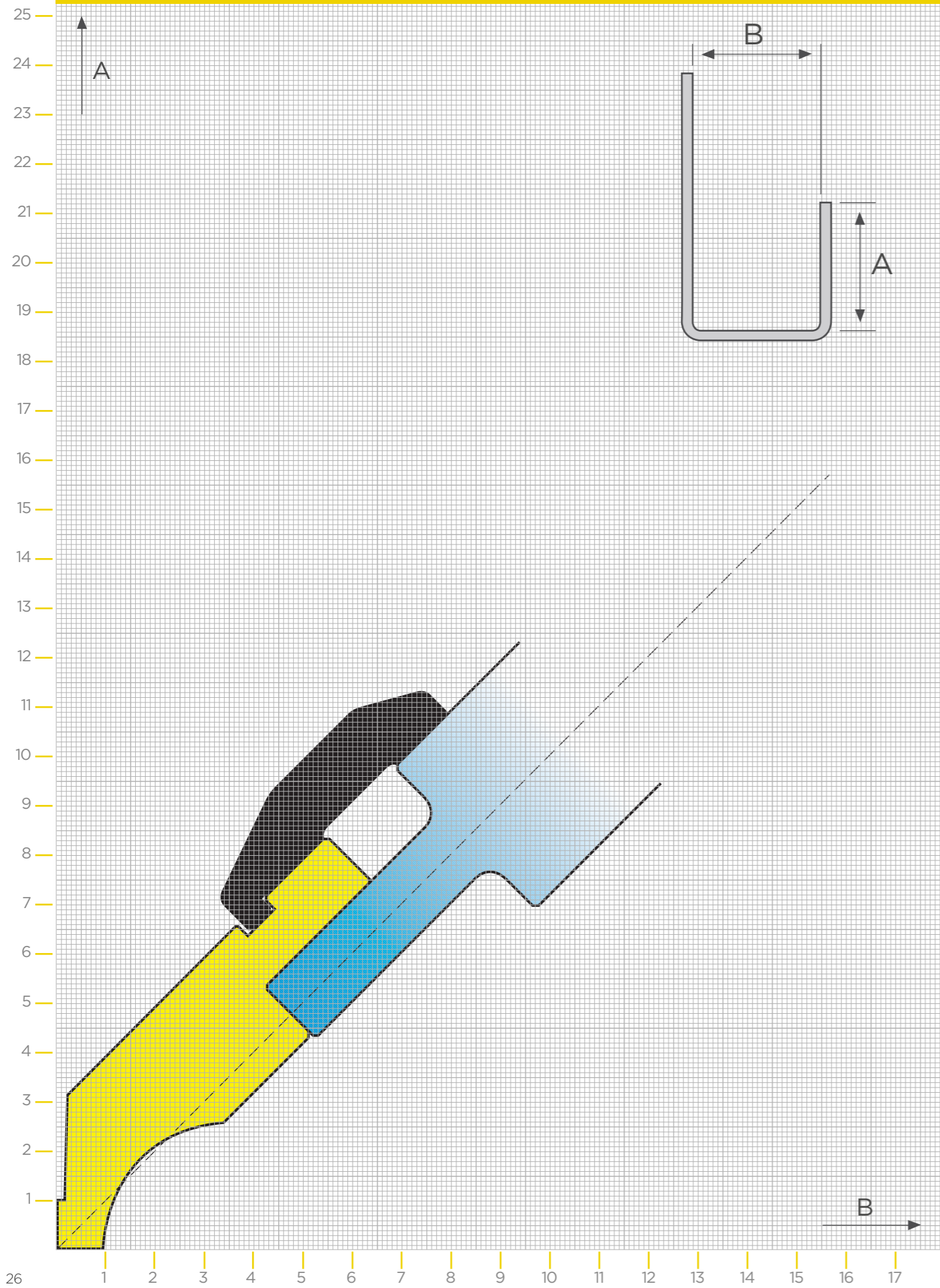

GRAFICO DEL LIMITE DI PIEGATURA / BEND LIMIT GRAPHIC

1014 - 1014 / A

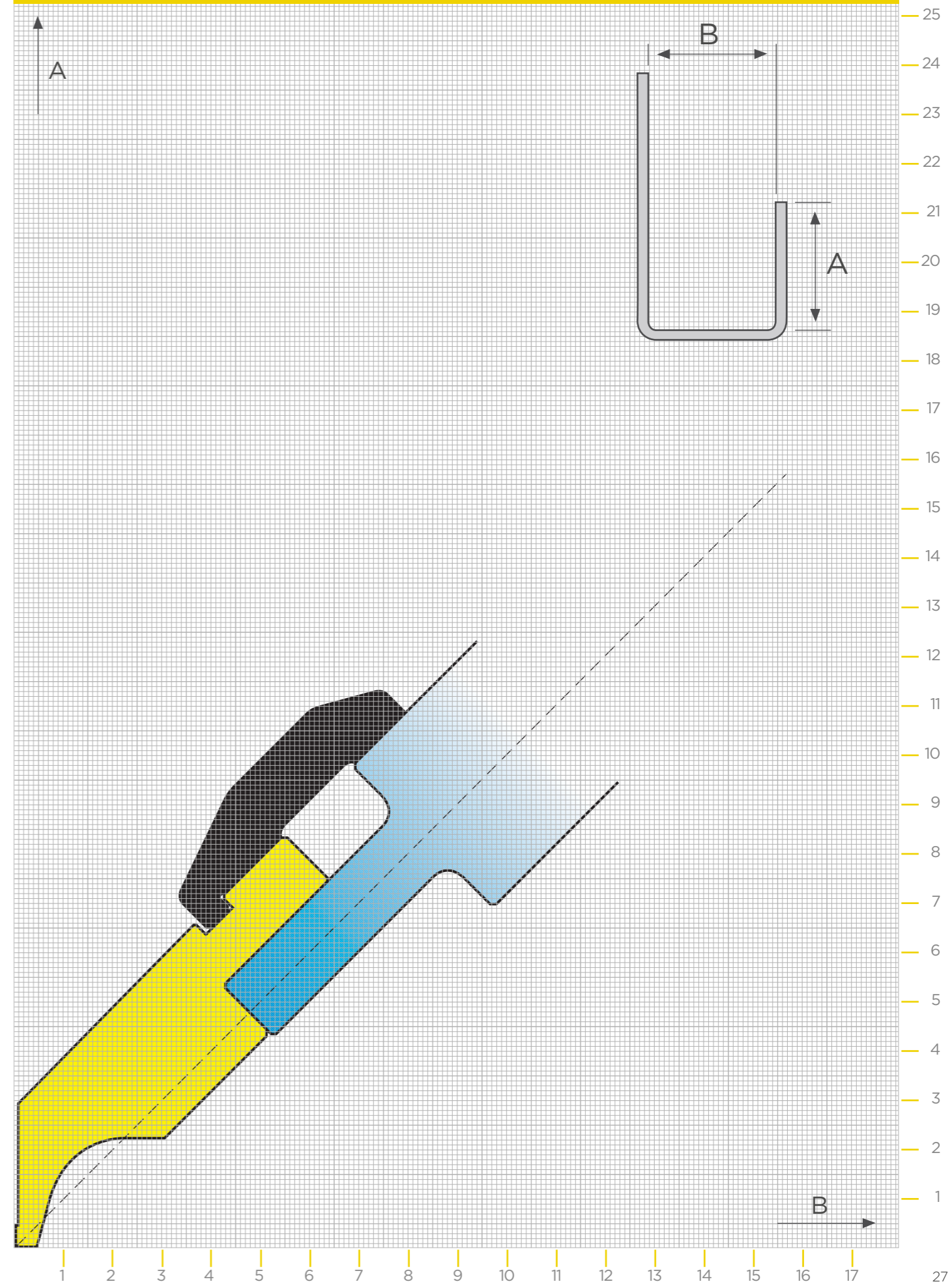

GRAFICO DEL LIMITE DI PIEGATURA / BEND LIMIT GRAPHIC

1014 / A / 6



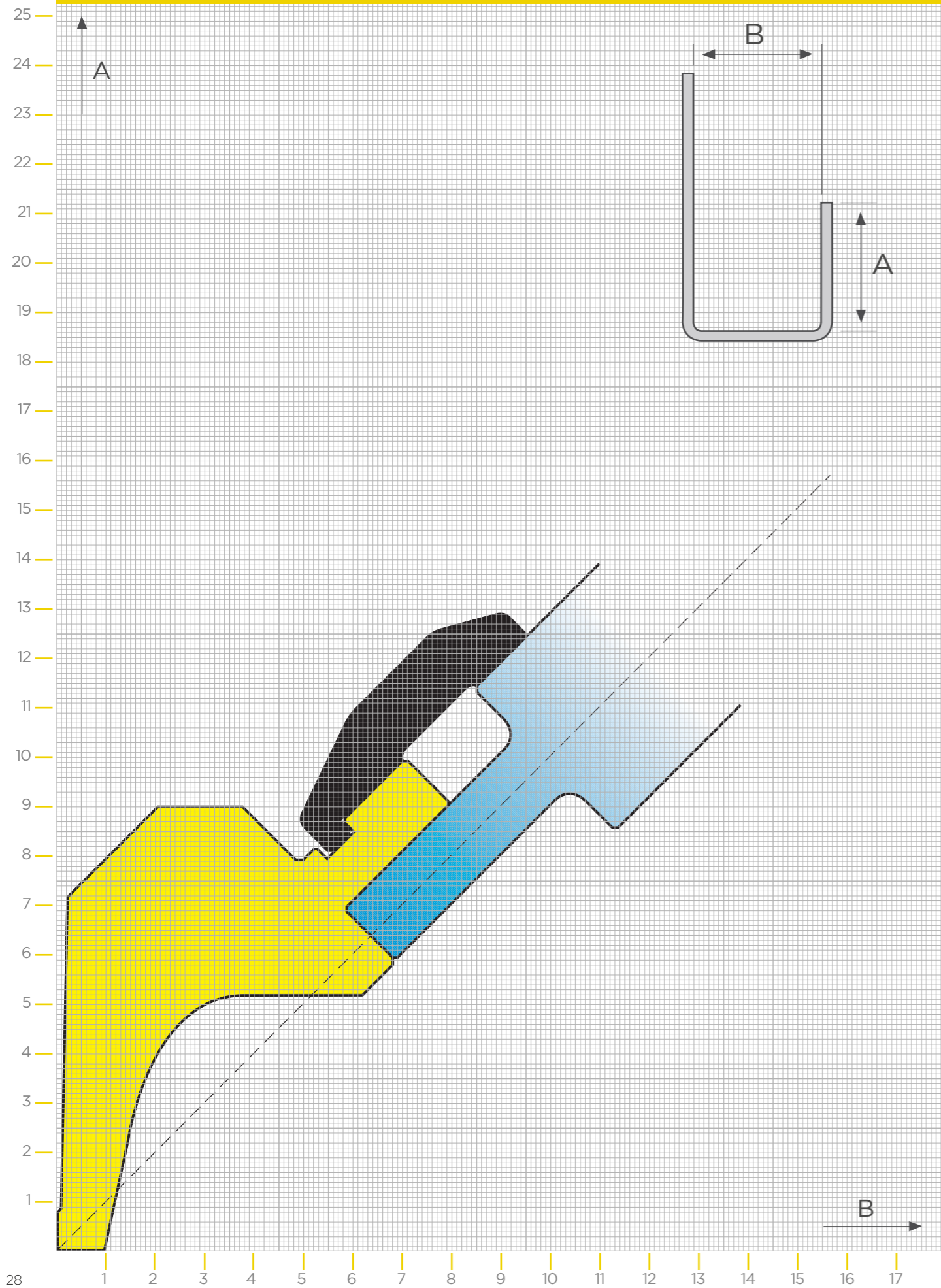

GRAFICO DEL LIMITE DI PIEGATURA / BEND LIMIT GRAPHIC

1015 - 1015 / A

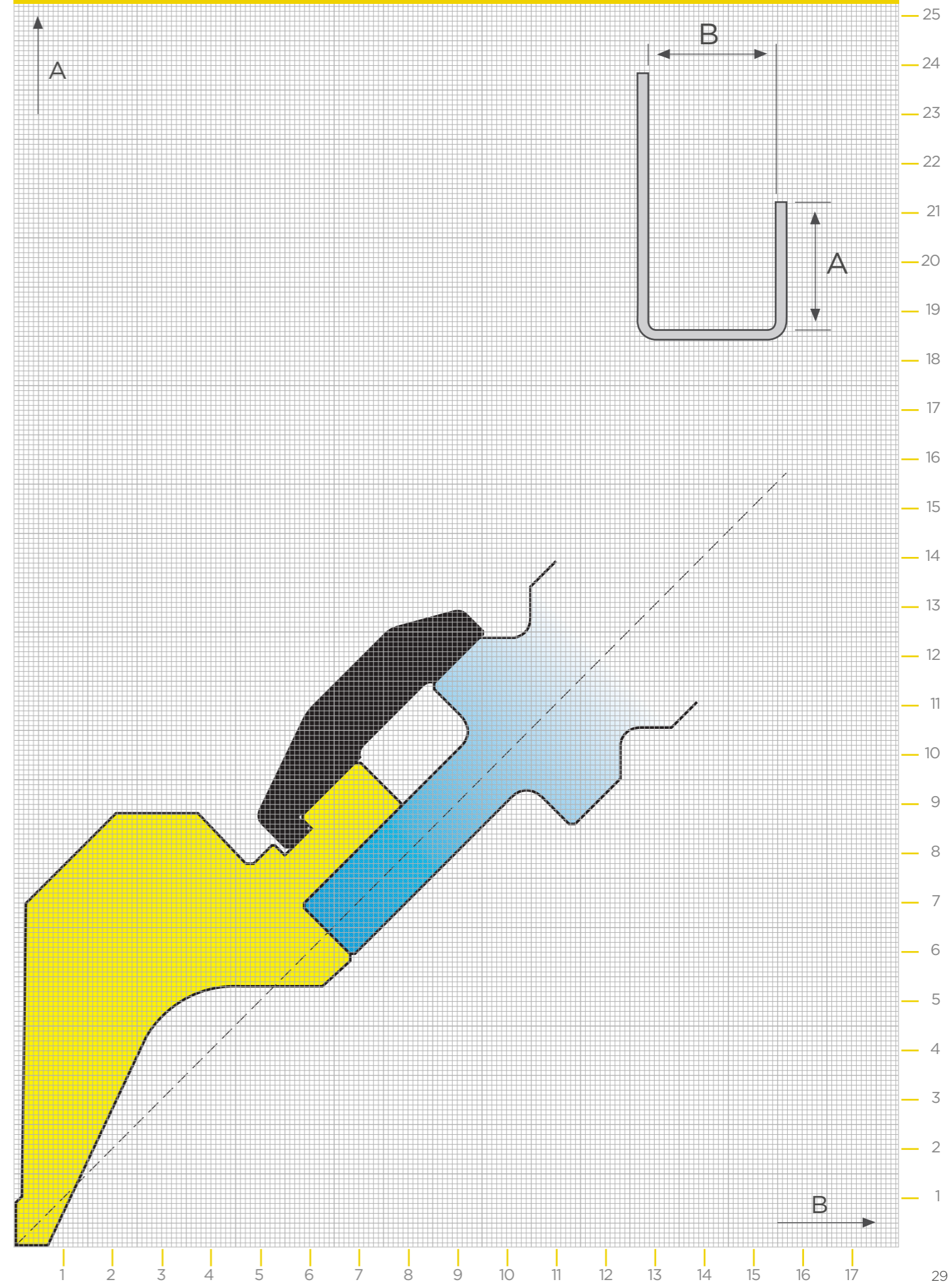

GRAFICO DEL LIMITE DI PIEGATURA / BEND LIMIT GRAPHIC

1020 / A

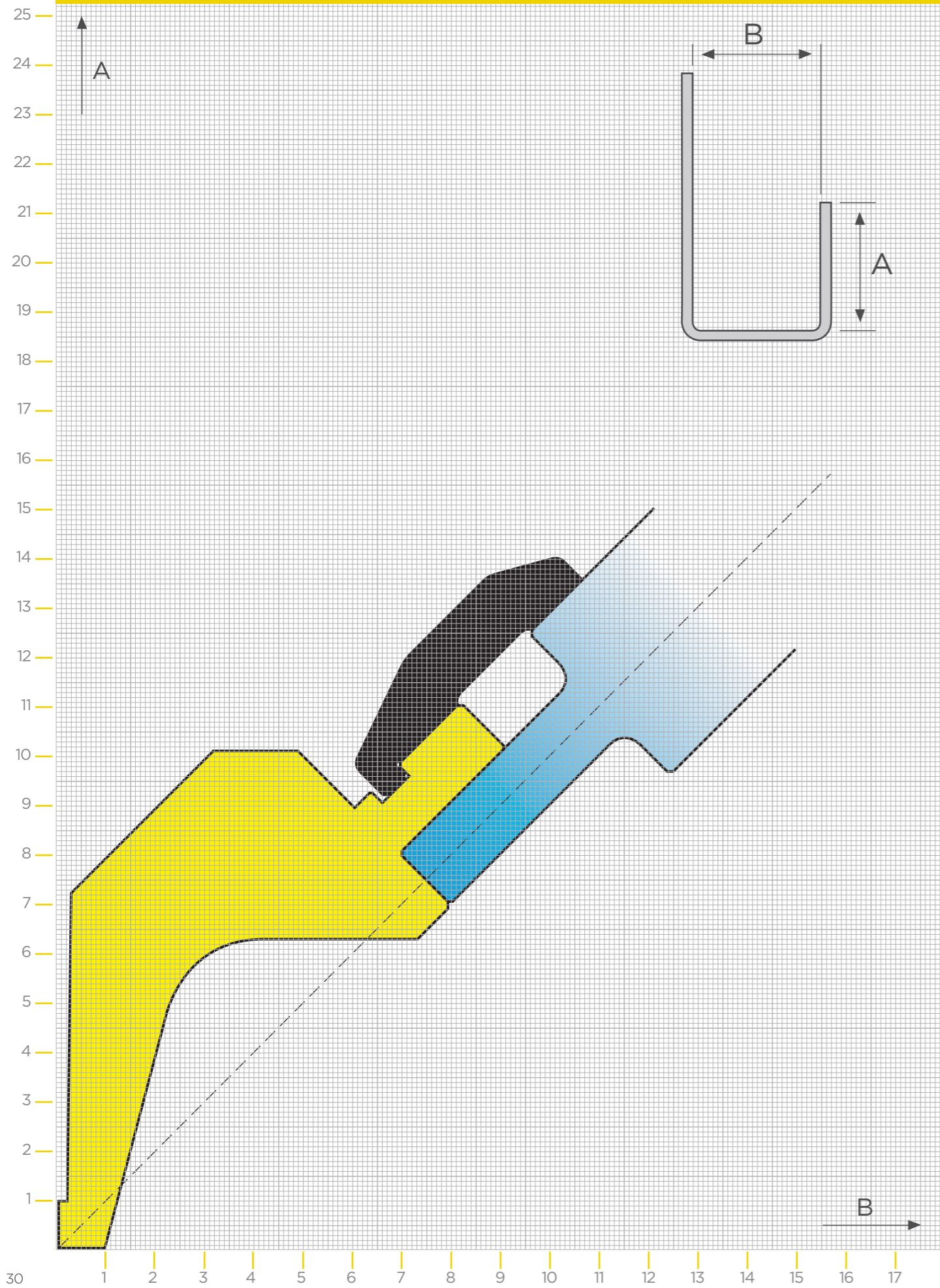

GRAFICO DEL LIMITE DI PIEGATURA / BEND LIMIT GRAPHIC

1023

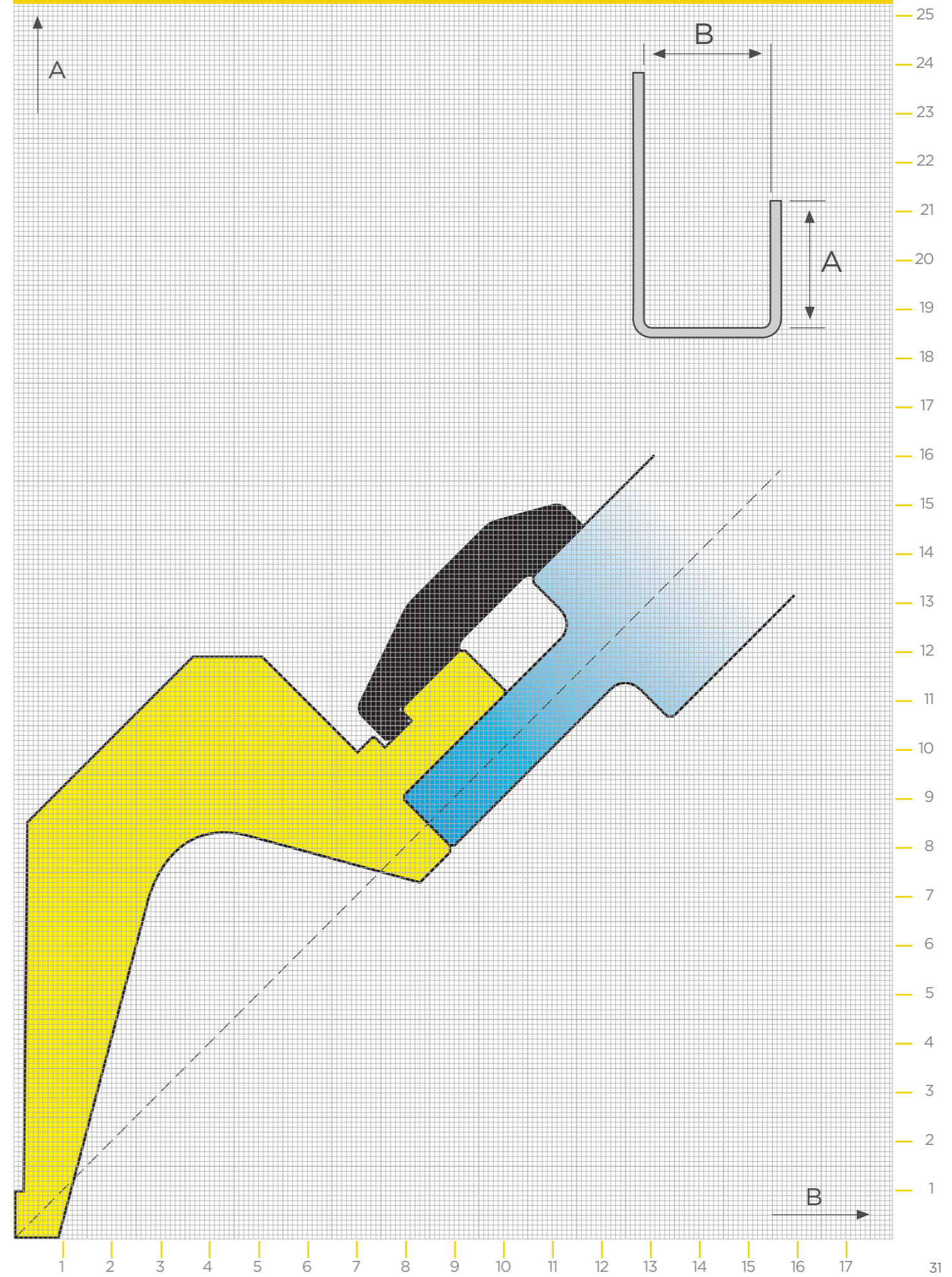

GRAFICO DEL LIMITE DI PIEGATURA / BEND LIMIT GRAPHIC

1024 / A

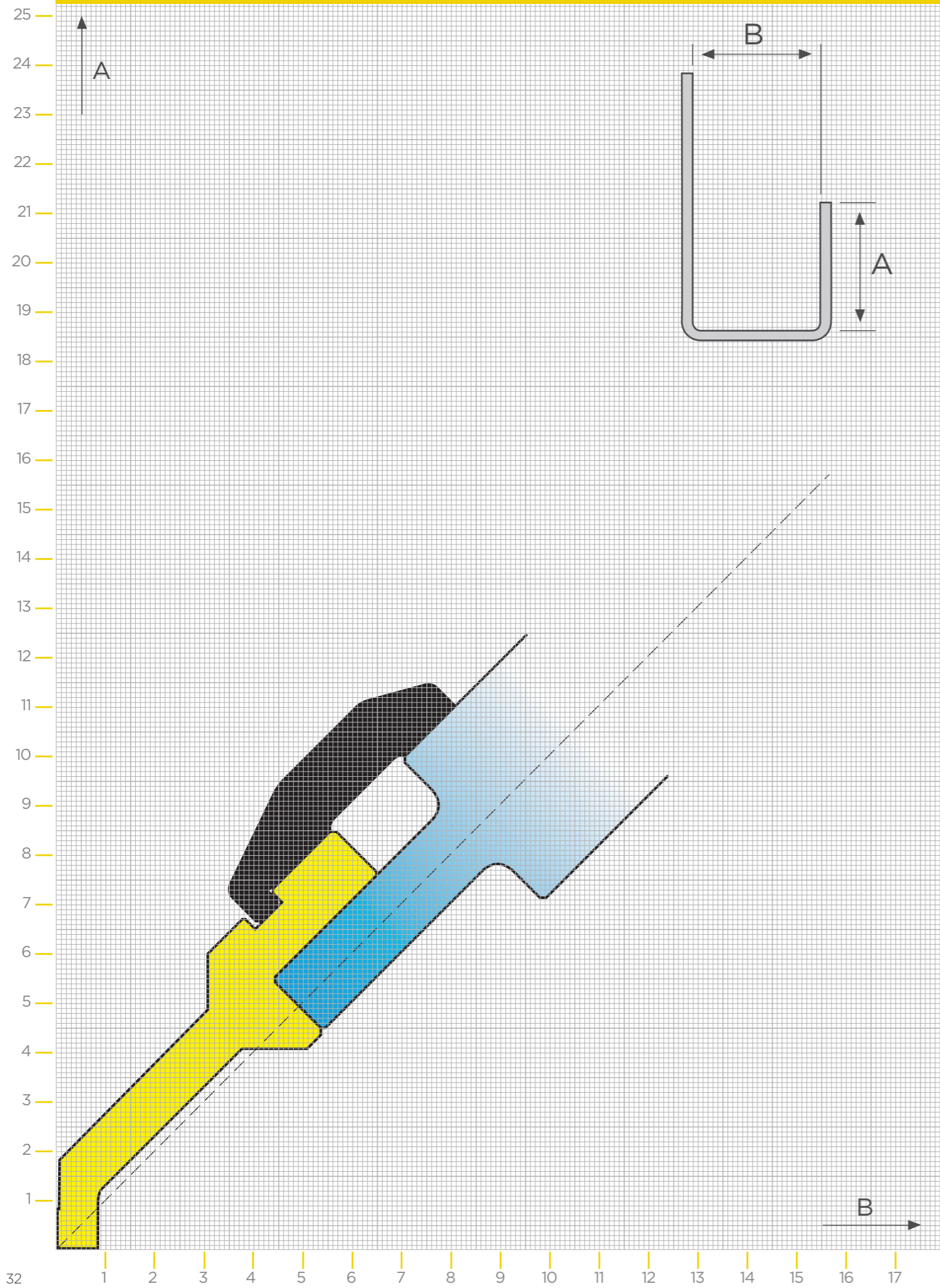

GRAFICO DEL LIMITE DI PIEGATURA / BEND LIMIT GRAPHIC

1022

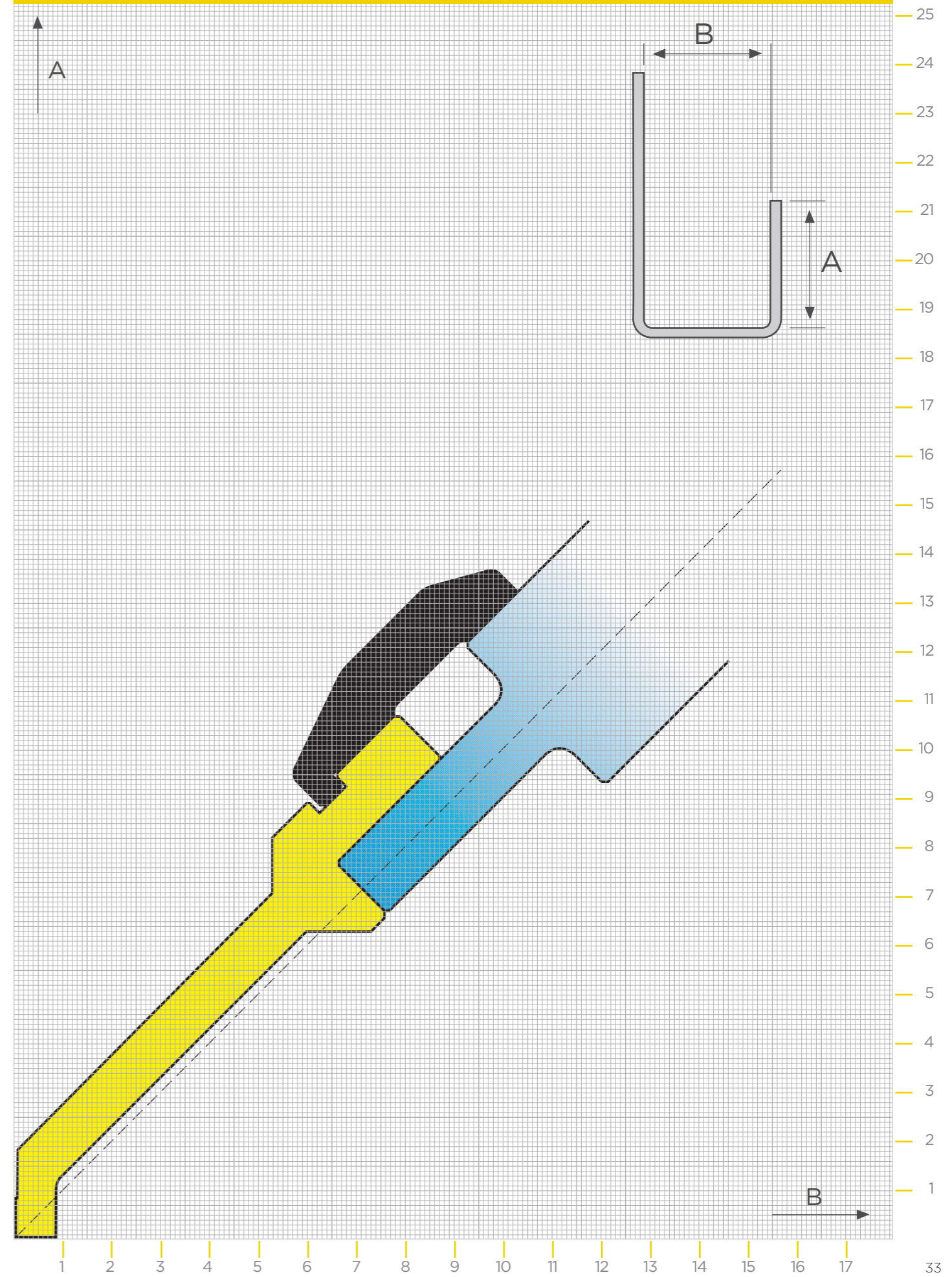

GRAFICO DEL LIMITE DI PIEGATURA / BEND LIMIT GRAPHIC

1021

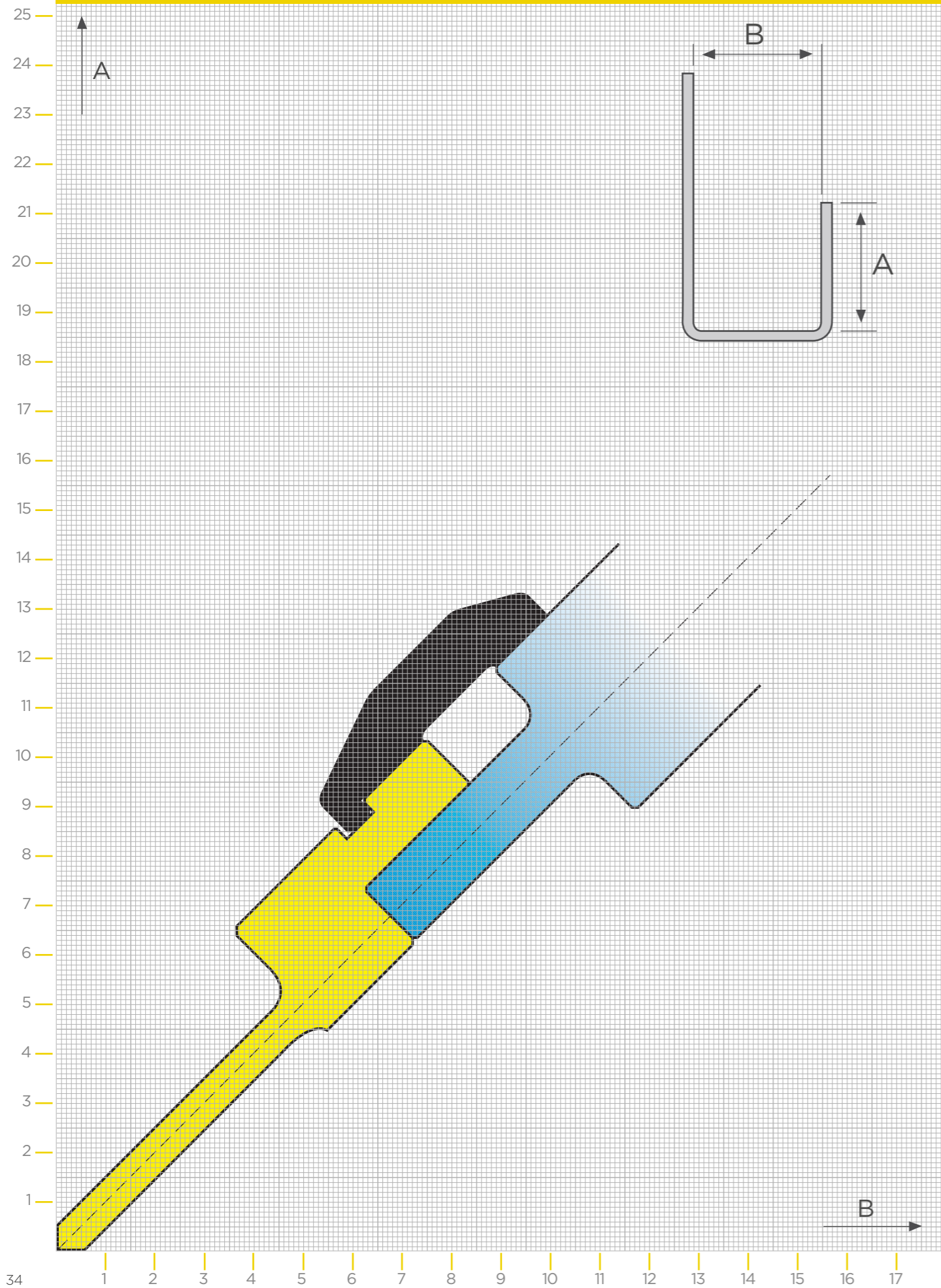

GRAFICO DEL LIMITE DI PIEGATURA / BEND LIMIT GRAPHIC

1027

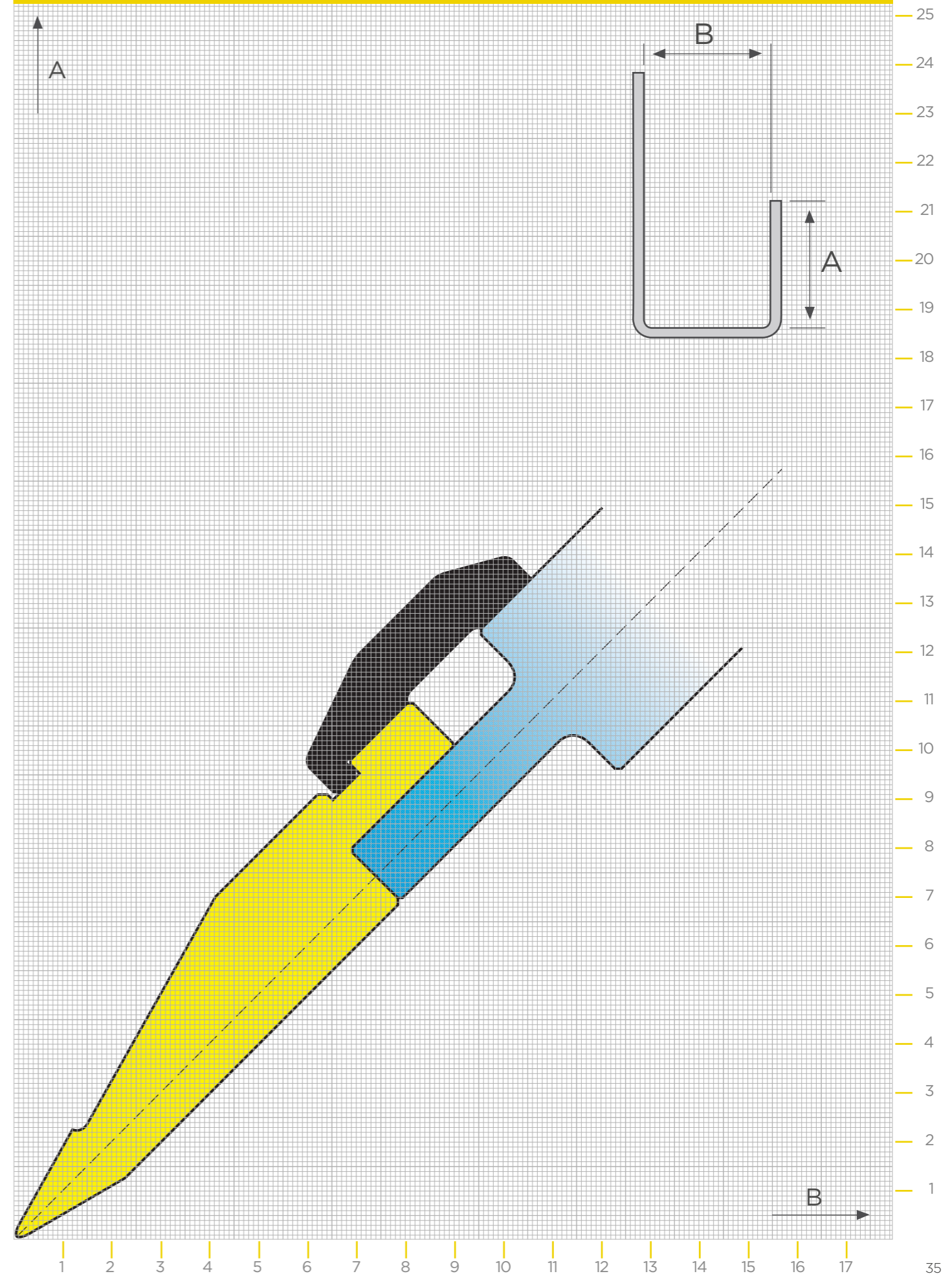
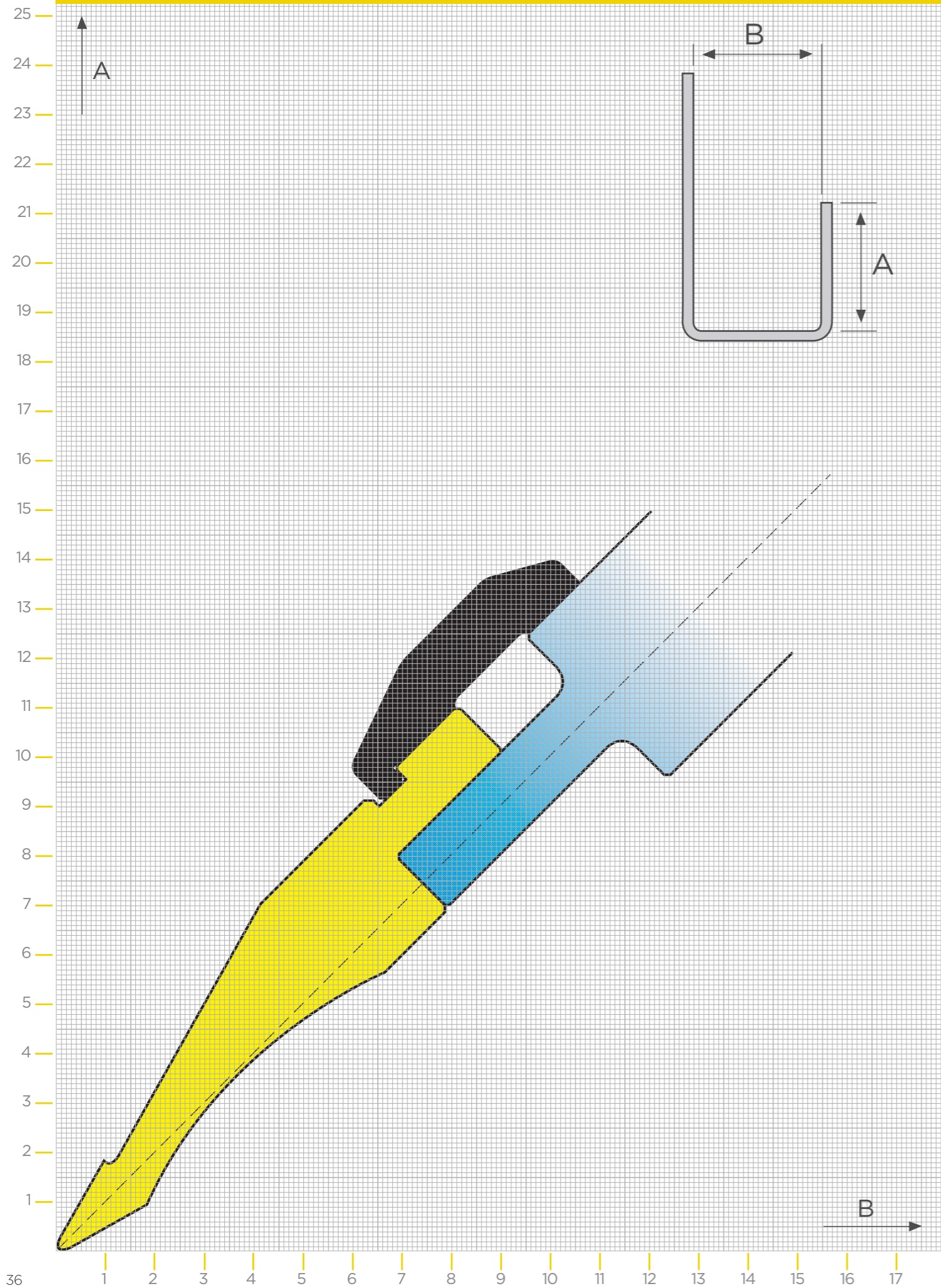

Notes

A large grid area for taking notes, with a vertical margin line on the left side.

# Notes

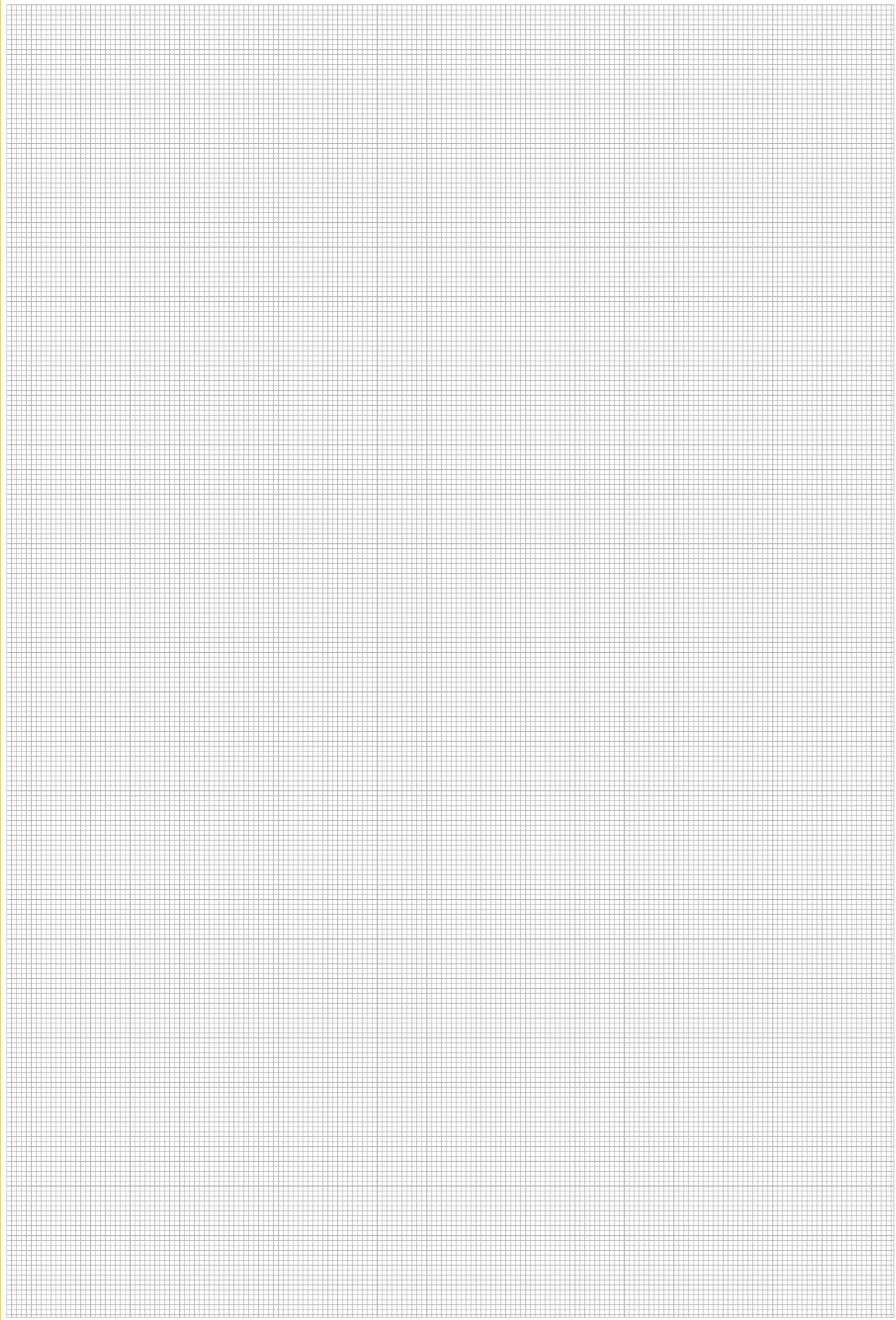

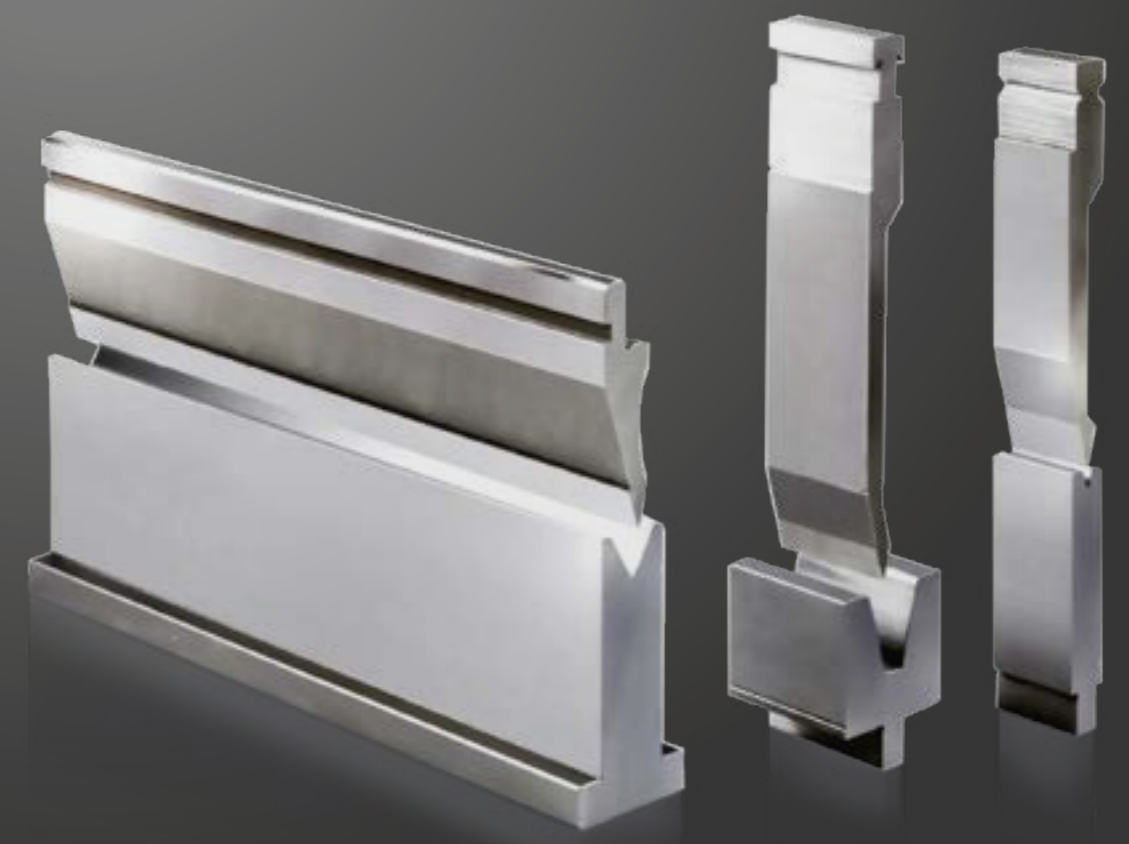

# MATRICI DIES

Utensili per presse piegatrici realizzati con standards di qualità superiore, temprati a induzione sulle parti di lavoro e totalmente rettificati. Lunghezza standard: 835mm; 414 mm; 835 frazionati.

Press Brake Tooling in best quality, induction hardened and ground on the working surfaces. Standard length: 835mm; 415 mm; 835 sectioned.

Abkantwerkzeuge in bester Qualität, induktionsgehärtet - arbeitsflächen geschliffen. Standardlängen: 835mm; 415 mm; 835 sektioniert.

Outils de pliage de qualité supérieure tempérés par induction avec faces principales rectifiées. Longueur standard: 835mm; 415 mm; 835 fractionné.

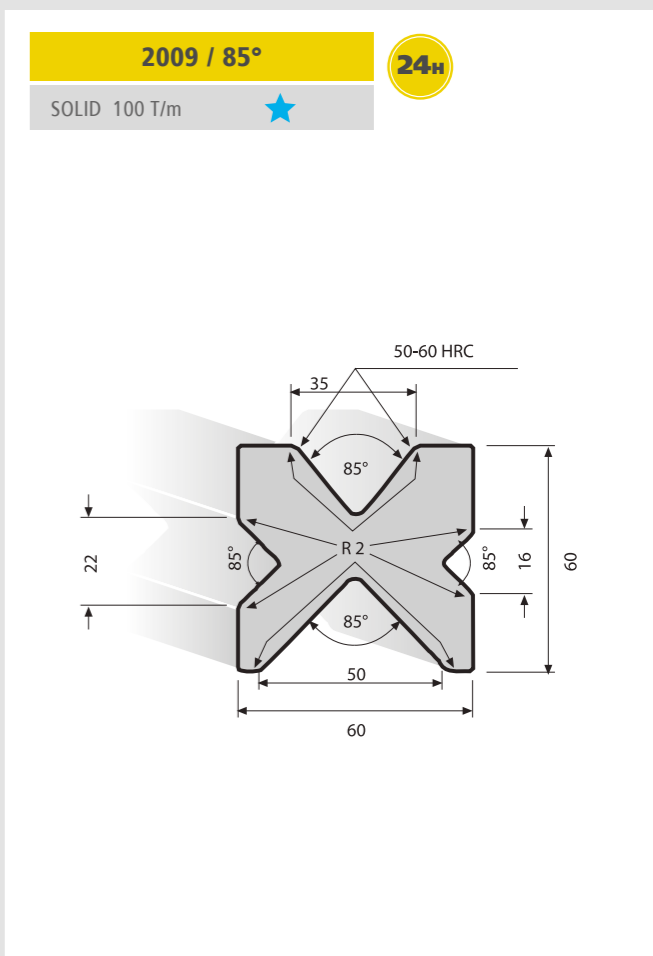
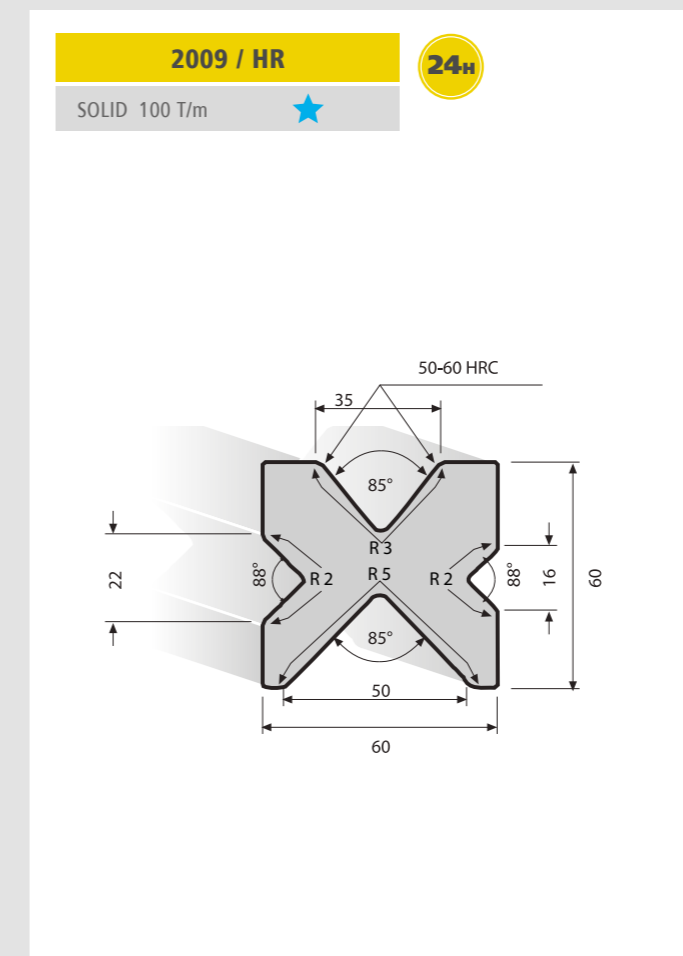
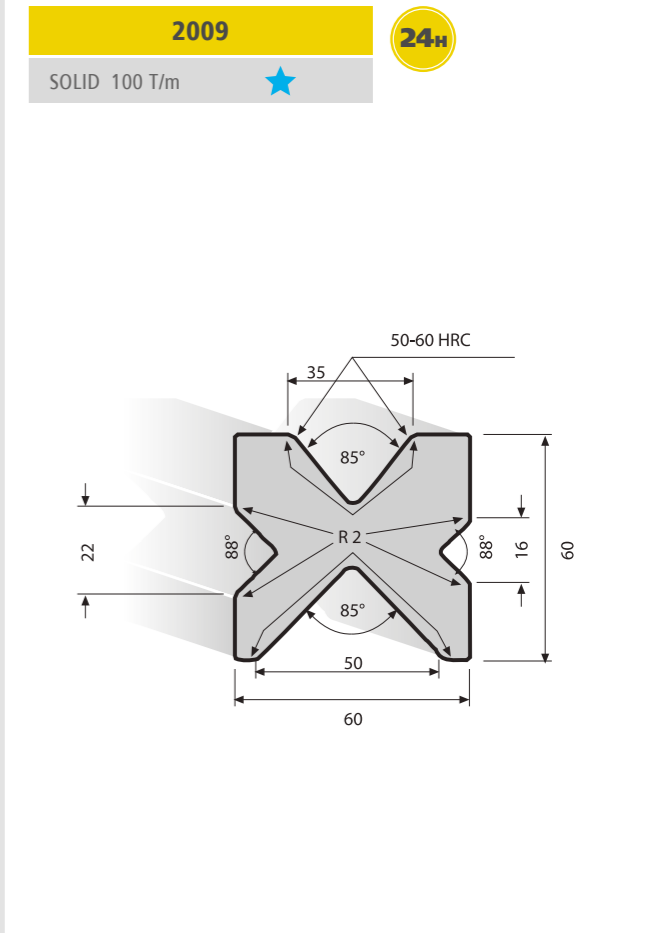
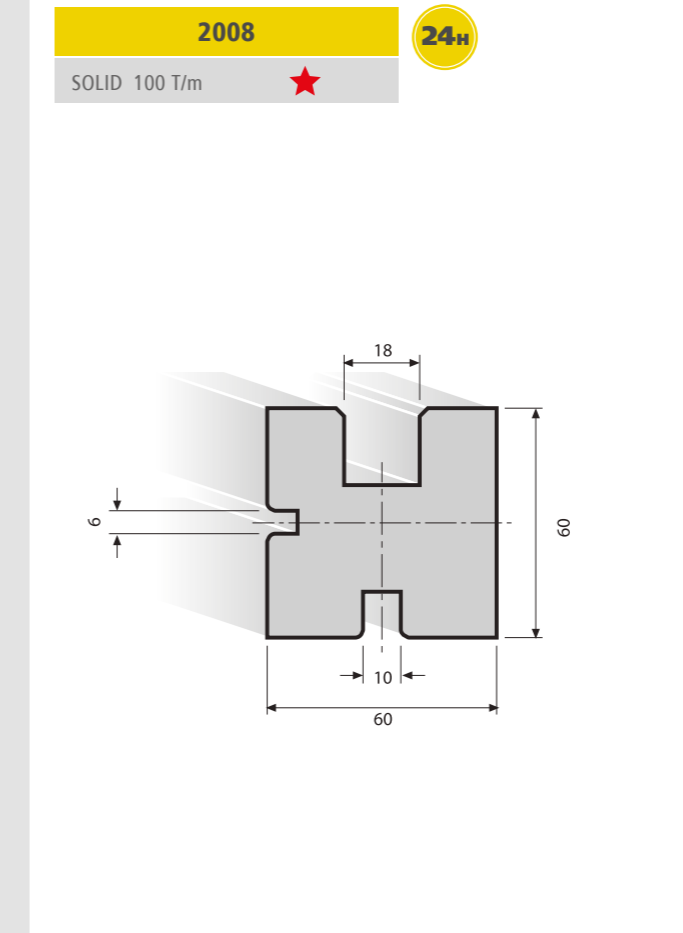

Abkantwerkzeuge in bester Qualität, induktionsgehärtet - arbeitsflächen geschliffen. Standardlängen: 835mm; 415 mm; 835 sektioniert.

Outils de pliage de qualité supérieure tempérés par induction avec faces principales rectifiées. Longueur standard: 835mm; 415 mm; 835 fractionné.

Utensili per presse piegatrici realizzati con standards di qualità superiore, temprati a induzione sulle parti di lavoro e totalmente rettificati. Lunghezza standard: 835mm; 414 mm; 835 frazionati.

Press Brake Tooling in best quality, induction hardened and ground on the working surfaces. Standard length: 835mm; 415 mm; 835 sectioned.

Abkantwerkzeuge in bester Qualität, induktionsgehärtet - arbeitsflächen geschliffen. Standardlängen: 835mm; 415 mm; 835 sektioniert.

Outils de pliage de qualité supérieure trempés par induction avec faces principales rectifiées. Longueur standard: 835mm; 415 mm; 835 fractionné.

**2009 / 85° / HR** 24H  
 SOLID 100 T/m ★

**2009 / 60°** 6W  
 SOLID 70 T/m ★

**2011 / A / 32 / 45°** 24H  
 SOLID 40 T/m ★

**2011 / 32 / 85°** 24H  
 SOLID 100 T/m ★

**2009 / SPEC** 6W  
 SOLID 70 T/m ★

**2011 / A / 18 / 30°** 24H  
 SOLID 80 T/m ★

**2011 / 40 / 45°** 24H  
 SOLID 100 T/m ★

**2011 / 40 / 85°** 24H  
 SOLID 100 T/m ★



Utensili per presse piegatrici realizzati con standards di qualità superiore, temprati a induzione sulle parti di lavoro e totalmente rettificati. Lunghezza standard: 835mm; 414 mm; 835 frazionati.

Press Brake Tooling in best quality, induction hardened and ground on the working surfaces. Standard length: 835mm; 415 mm; 835 sectioned.

Abkantwerkzeuge in bester Qualität, induktionsgehärtet - arbeitsflächen geschliffen. Standardlängen: 835mm; 415 mm; 835 sektioniert.

Outils de pliage de qualité supérieure trempés par induction avec faces principales rectifiées. Longueur standard: 835mm; 415 mm; 835 fractionné.

2011 / 50 / 45° **24H**  
SOLID 90 T/m ★

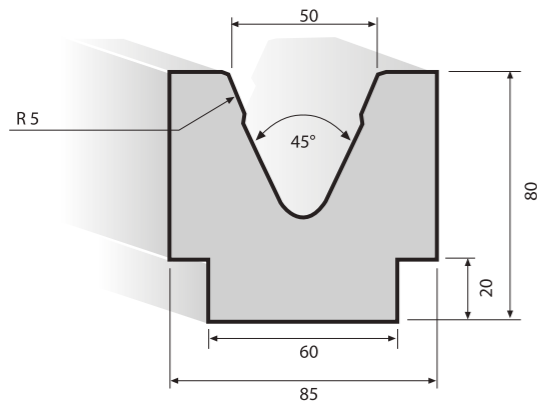

2011 / 50 / 85° **24H**  
SOLID 100 T/m ★

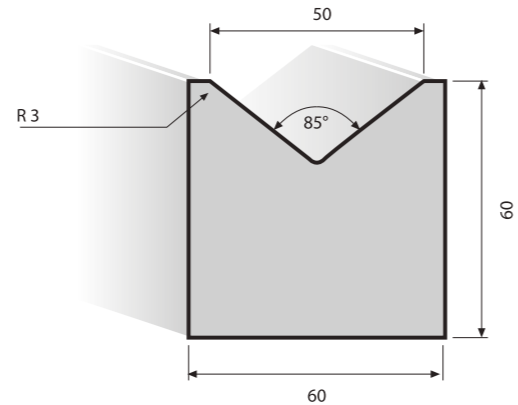

2011 / 80 / 45° **24H**  
SOLID 100 T/m ★

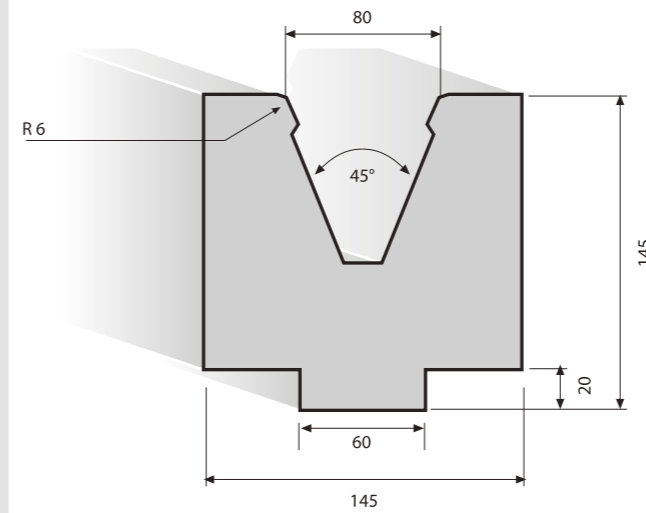

2011 / 80 / 60° **24H**  
SOLID 100 T/m ★

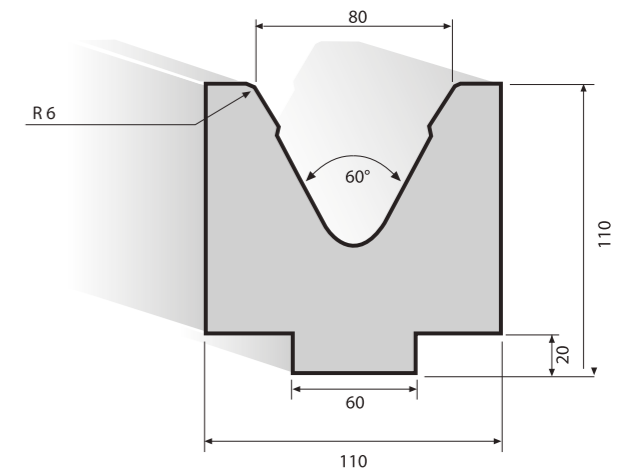

2011 / 63 / 60° **24H**  
SOLID 100 T/m ★

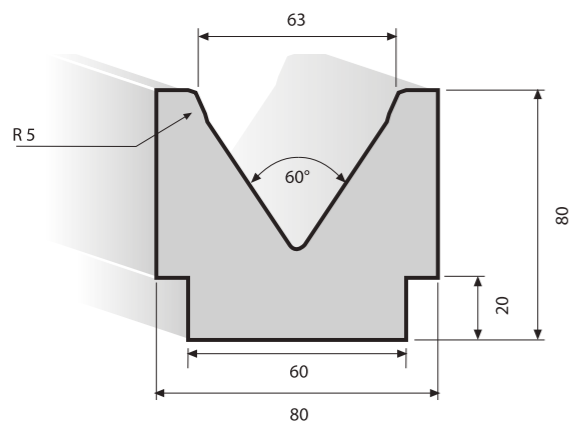

2011 / A / 63 / 85° **24H**  
SOLID 100 T/m ★

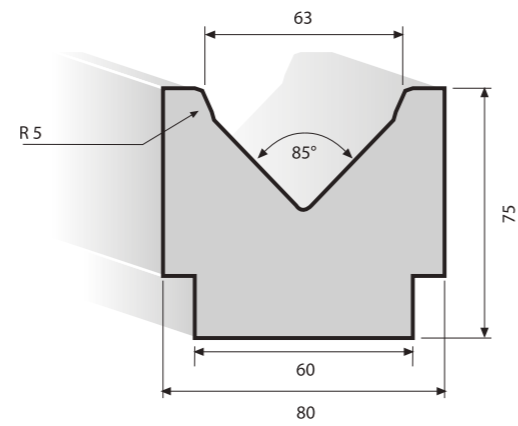

2011 / 80 / 85° **24H**  
SOLID 100 T/m ★

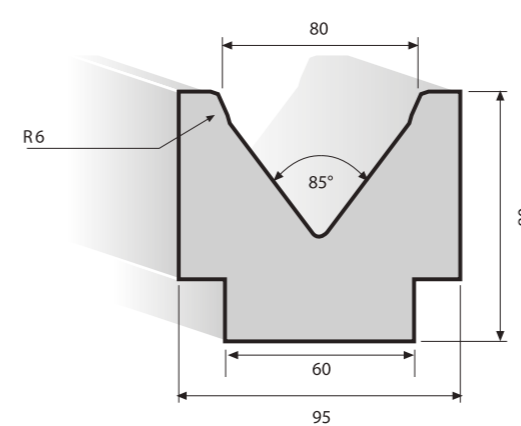

2011 / 100 / 80° **24H**  
SOLID 100 T/m ★

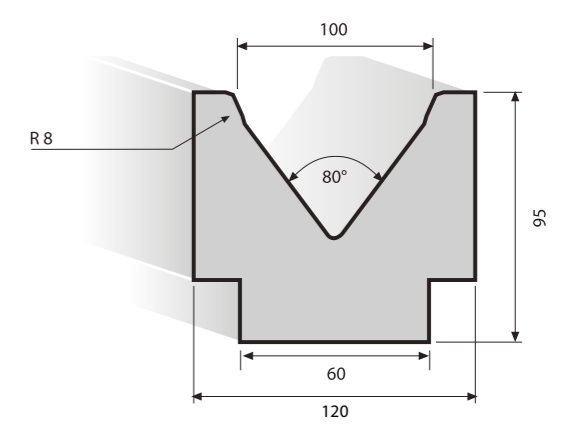

Utensili per presse piegatrici realizzati con standards di qualità superiore, temprati a induzione sulle parti di lavoro e totalmente rettificati. Lunghezza standard: 835mm; 414 mm; 835 frazionati.

Press Brake Tooling in best quality, induction hardened and ground on the working surfaces. Standard lenght: 835mm; 415 mm; 835 sektioniert.

Abkantwerkzeuge in bester Qualität, induktionsgehärtet - arbeitsflächen geschliffen. Standardlängen: 835mm; 415 mm; 835 sektioniert.

Outils de pliage de qualité supérieure trempés par induction avec faces principales rectifiées. Longueur standard: 835mm; 415 mm; 835 fractionné.

2011 / 125 / 80°

24H

SOLID 100 T/m ★

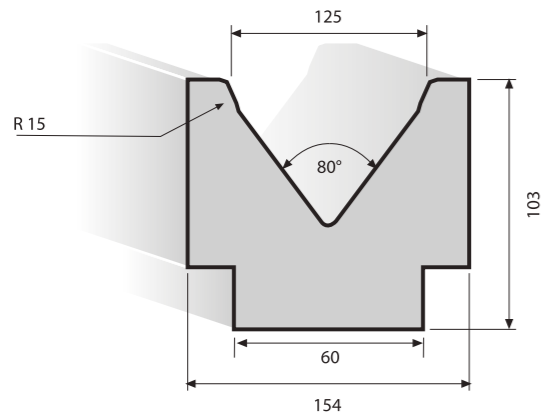

2011 / 160 / 80°

24H

SOLID 100 T/m ★

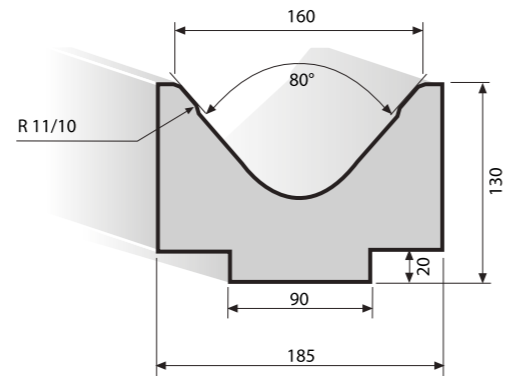

2012

24H

$\alpha = 88^\circ - 90^\circ$

SOLID 100 T/m ★

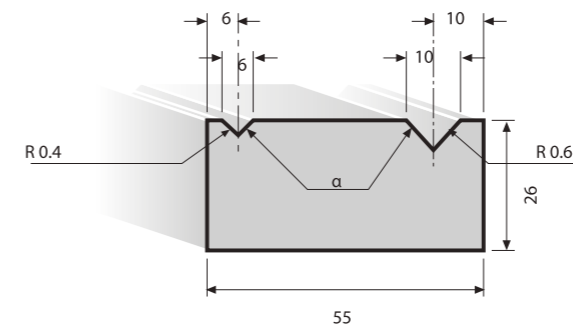

2012 / A / 90°

24H

SOLID 80 T/m ★

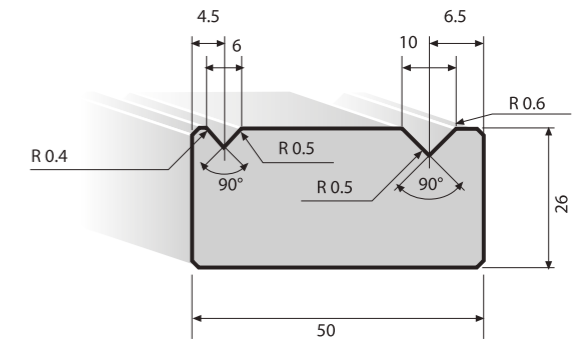

2011 / 200 / 70°

24H

SOLID 150 T/m ★

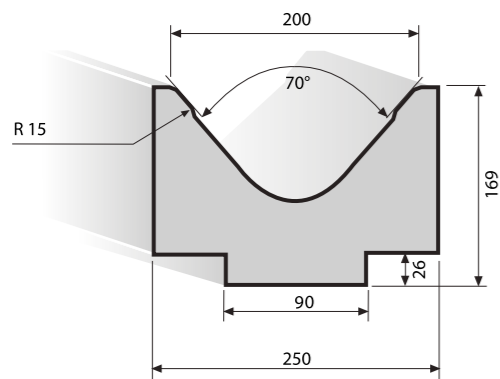

2011 / 220 / 70°

24H

SOLID 200 T/m ★

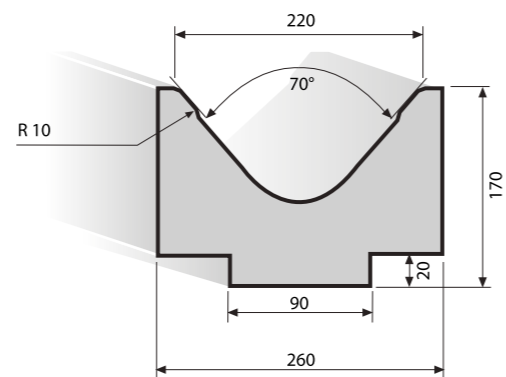

2012 / 60°

24H

SOLID 80 T/m ★

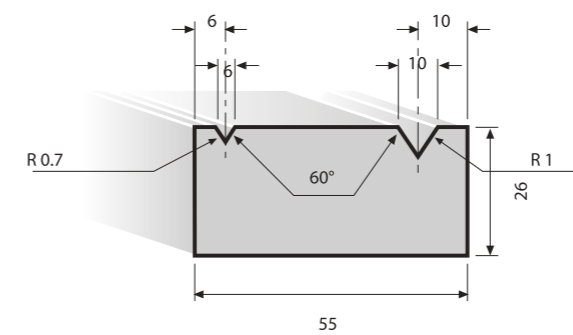

2012 / 35°

24H

SOLID 30 T/m ★

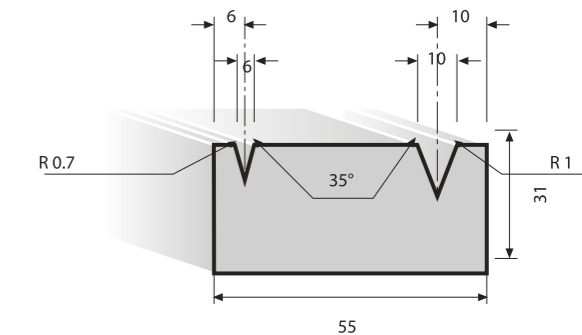

Utensili per presse piegatrici realizzati con standards di qualità superiore, temprati a induzione sulle parti di lavoro e totalmente rettificati. Lunghezza standard: 835mm; 414 mm; 835 frazionati.

Press Brake Tooling in best quality, induction hardened and ground on the working surfaces. Standard length: 835mm; 415 mm; 835 sectioned.

Abkantwerkzeuge in bester Qualität, induktionsgehärtet - arbeitsflächen geschliffen. Standardlängen: 835mm; 415 mm; 835 sektioniert.

Outils de pliage de qualité supérieure trempés par induction avec faces principales rectifiées. Longueur standard: 835mm; 415 mm; 835 fractionné.

**2013** 24H

$\alpha = 88^\circ - 90^\circ$

SOLID 100 T/m ★

**2013 / A / 90°** 24H

SOLID 80 T/m ★

**2014 / 88°** 24H

SOLID 100 T/m ★

**2014 / A / 88°** 24H

SOLID 80 T/m ★

**2013 / 60°** 24H

SOLID 80 T/m ★

**2013 / 35°** 24H

SOLID 30 T/m ★

**2014 / 60°** 24H

SOLID 80 T/m ★

**2015 / 88°** 24H

SOLID 100 T/m ★

Utensili per presse piegatrici realizzati con standards di qualità superiore, temprati a induzione sulle parti di lavoro e totalmente rettificati. Lunghezza standard: 835mm; 414 mm; 835 frazionati.

Press Brake Tooling in best quality, induction hardened and ground on the working surfaces. Standard length: 835mm; 415 mm; 835 sectioned.

Abkantwerkzeuge in bester Qualität, induktionsgehärtet - arbeitsflächen geschliffen. Standardlängen: 835mm; 415 mm; 835 sektioniert.

Outils de pliage de qualité supérieure trempés par induction avec faces principales rectifiées. Longueur standard: 835mm; 415 mm; 835 fractionné.

**2015 / A / 88°** **24H**  
SOLID 80 T/m ★

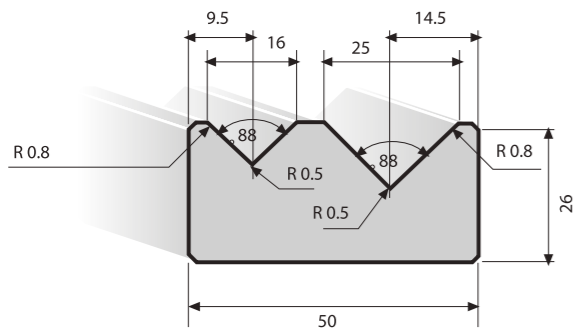

**2015 / 60°** **24H**  
SOLID 80 T/m ★

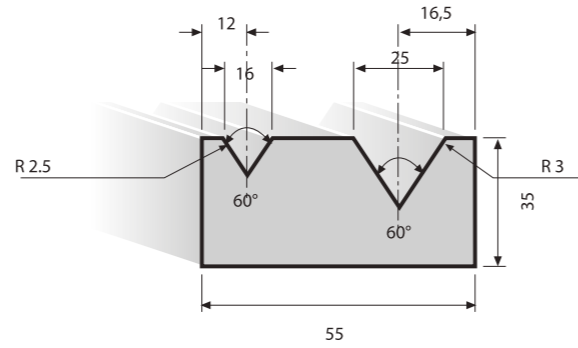

**2030 / 30°** **24H**  
V= 6 mm | R= 0,6 mm  
V= 8 mm | R= 0,8 mm  
V= 10 mm | R= 1 mm  
V= 12 mm | R= 1,5 mm  
V= 16 mm | R= 2 mm  
V= 20 mm | R= 2,5 mm  
V= 25 mm | R= 3 mm  
H= 80 mm  
H= 120 mm  
SOLID 40 T/m ★

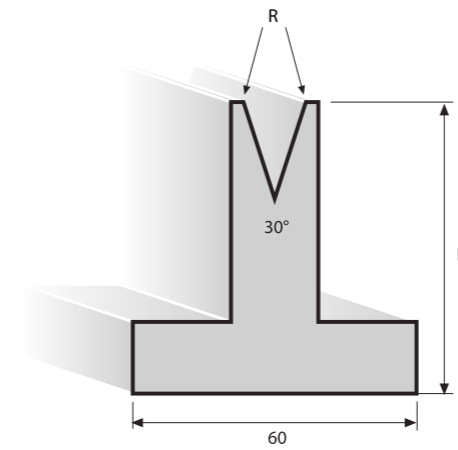

**2035 / 35°** **24H**  
V= 8 mm | R= 1,5 mm | H= 80 mm  
V= 12 mm | R= 2 mm | H= 120 mm  
SOLID 30 T/m ★

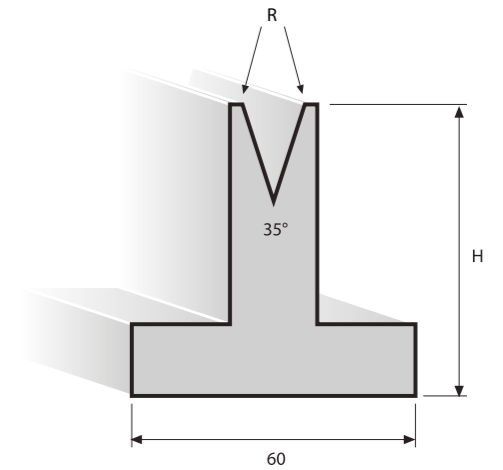

**2016 / α** **24H**  
α= 88° -90°  
SOLID 70 T/m ★

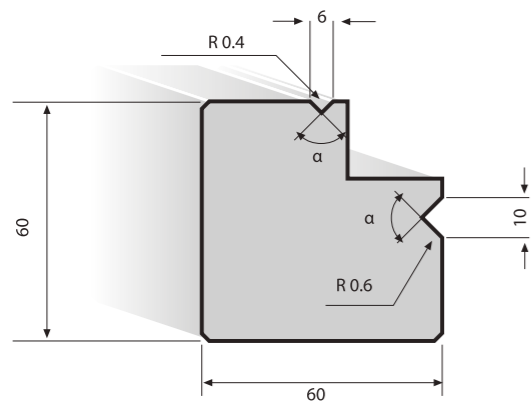

**2017 / α** **24H**  
α= 88° -90°  
SOLID 70 T/m ★

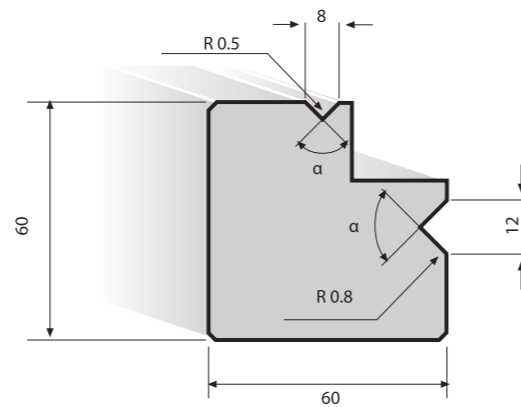

**2045 / 45°** **24H**  
V= 10 mm | R= 1 mm  
V= 12 mm | R= 1,5 mm  
V= 16 mm | R= 2 mm  
V= 20 mm | R= 2,5 mm  
V= 25 mm | R= 3 mm  
H= 80 mm  
H= 120 mm  
SOLID 70 T/m ★

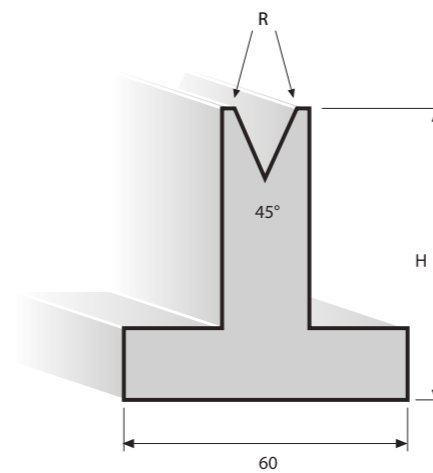

**2060 / 60°** **24H**  
V= 6 mm | R= 1,5 mm  
V= 8 mm | R= 1,5 mm  
V= 10 mm | R= 2 mm  
V= 12 mm | R= 2,5 mm  
V= 16 mm | R= 1,5 mm  
V= 20 mm | R= 2 mm  
V= 25 mm | R= 3 mm  
H= 80 mm  
H= 120 mm  
SOLID 70 T/m ★

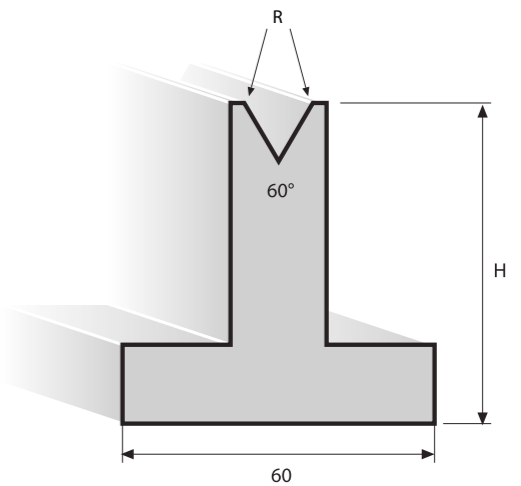

Utensili per presse piegatrici realizzati con standards di qualità superiore, temprati a induzione sulle parti di lavoro e totalmente rettificati. Lunghezza standard: 835mm; 414 mm; 835 frazionati.

Press Brake Tooling in best quality, induction hardened and ground on the working surfaces. Standard length: 835mm; 415 mm; 835 sectioned.

Abkantwerkzeuge in bester Qualität, induktionsgehärtet - arbeitsflächen geschliffen. Standardlängen: 835mm; 415 mm; 835 sektioniert.

Outils de pliage de qualité supérieure trempés par induction avec faces principales rectifiées. Longueur standard: 835mm; 415 mm; 835 fractionné.

**2085 / 85°** 24H

V= 6 mm	R= 2,75 mm
V= 8 mm	R= 2,75 mm
V= 10 mm	R= 2,75 mm
V= 12 mm	R= 2,75 mm
V= 16 mm	R= 2,75 mm
V= 20 mm	R= 3 mm
V= 25 mm	R= 3 mm

H= 80 mm  
H= 120 mm

SOLID 95 T/m ★

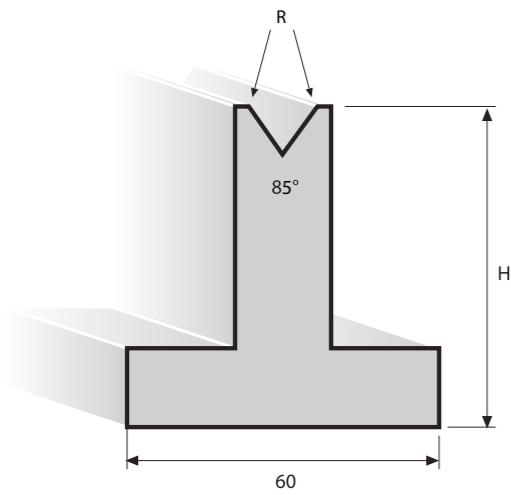

**2088 / 88°** 24H

V= 6 mm	R= 1,5 mm
V= 8 mm	R= 1,5 mm
V= 10 mm	R= 2 mm
V= 12 mm	R= 2,5 mm
V= 16 mm	R= 2,5 mm
V= 20 mm	R= 3 mm
V= 25 mm	R= 3 mm

H= 80 mm  
H= 120 mm

SOLID 95 T/m ★

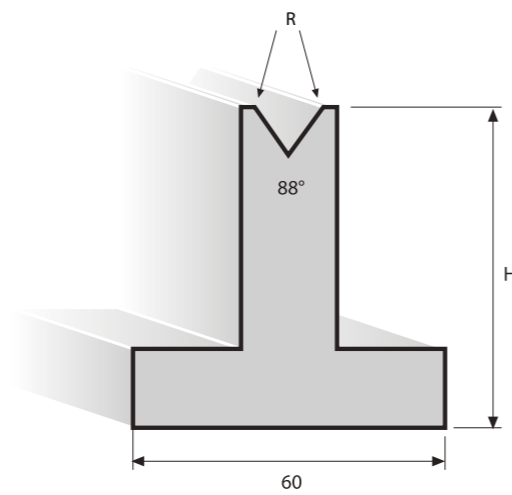

**2188 / A / 88°** 24H

V= 6 mm
V= 8 mm
V= 10 mm
V= 12 mm
V= 14 mm

SOLID 95 T/m ★ ★ ★

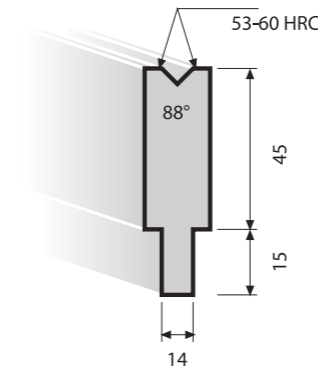

**2190 / A / 90°** 24H

V= 6 mm
V= 8 mm
V= 10 mm
V= 12 mm

SOLID 95 T/m ★ ★ ★

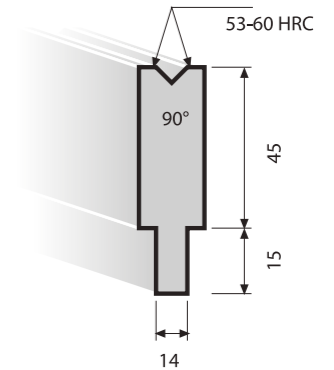

**2090 / 90°** 24H

V= 6 mm	R= 1,5 mm
V= 8 mm	R= 1,5 mm
V= 10 mm	R= 2 mm
V= 12 mm	R= 2,5 mm

SOLID 95 T/m ★

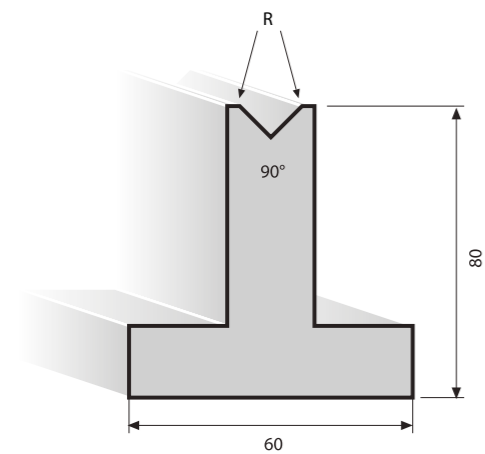

**2130 / 30°** 24H

V= 6 mm
V= 8 mm
V= 10 mm
V= 12 mm
V= 16 mm
V= 20 mm
V= 24 mm

SOLID 30 T/m ★ ★ ★

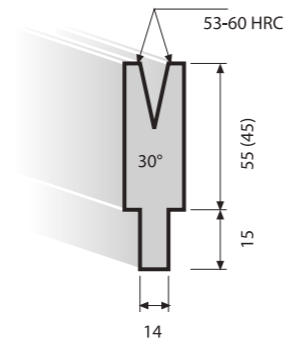

**2019 / A / α** 24H

α= 88° -90°

SOLID 60 T/m ★

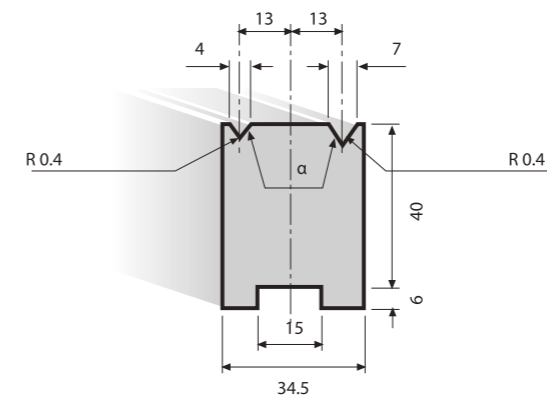

**2020 / A / α** 24H

α= 88° -90°

SOLID 70 T/m ★

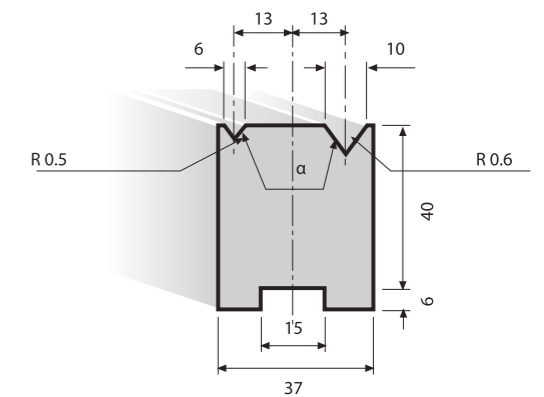

Utensili per presse piegatrici realizzati con standards di qualità superiore, temprati a induzione sulle parti di lavoro e totalmente rettificati. Lunghezza standard: 835mm; 414 mm; 835 frazionati.

Press Brake Tooling in best quality, induction hardened and ground on the working surfaces. Standard length: 835mm; 415 mm; 835 sectioned.

Abkantwerkzeuge in bester Qualität, induktionsgehärtet - arbeitsflächen geschliffen. Standardlängen: 835mm; 415 mm; 835 sektioniert.

Outils de pliage de qualité supérieure trempés par induction avec faces principales rectifiées. Longueur standard: 835mm; 415 mm; 835 fractionné.

2021 / A /  $\alpha$

24H

$\alpha = 88^\circ - 90^\circ$

SOLID 75 T/m

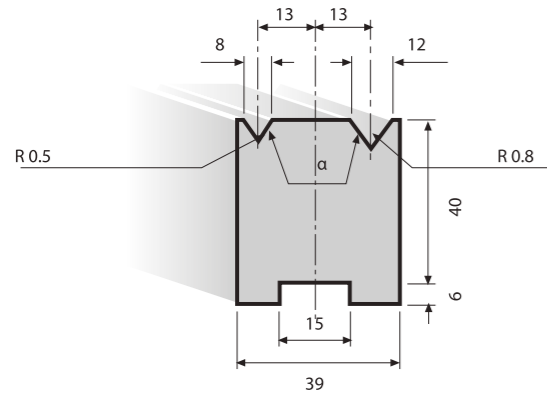

2022 / A /  $88^\circ$

24H

SOLID 100 T/m

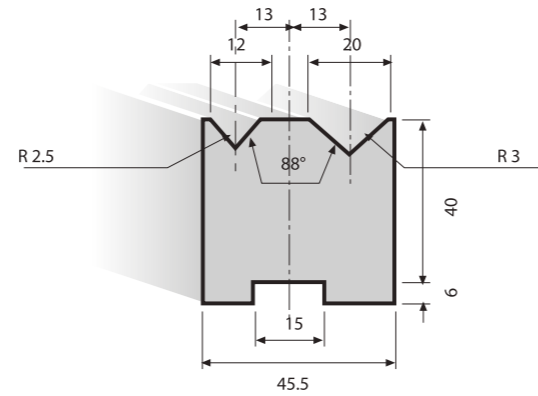

2025 / A /  $30^\circ$

24H

SOLID 30 T/m

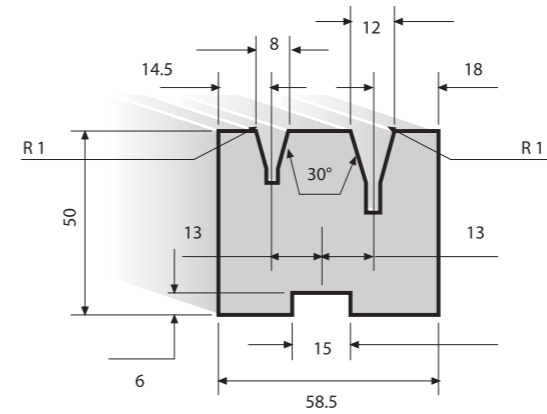

2026 / A /  $30^\circ$

24H

SOLID 30 T/m

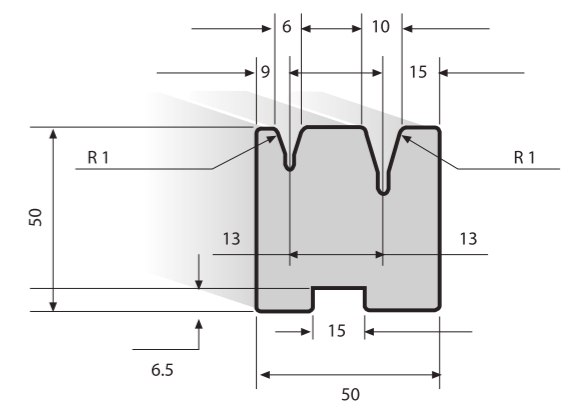

2023 / A /  $88^\circ$

24H

SOLID 100 T/m

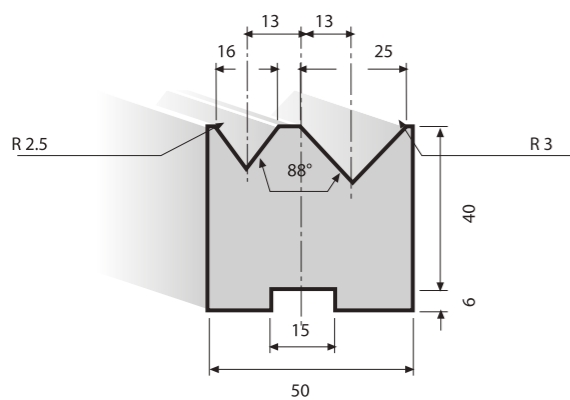

2024 / A /  $88^\circ$

24H

SOLID 100 T/m

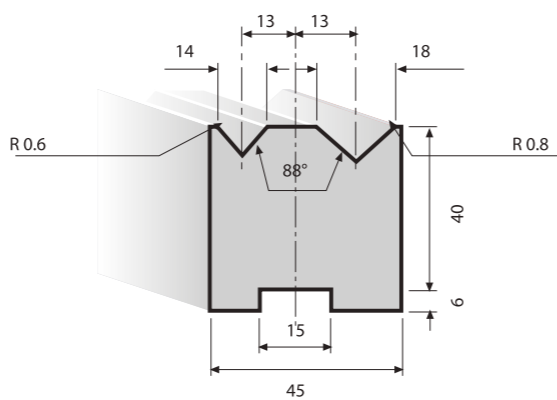

2027 / A /  $75^\circ$

24H

SOLID 50 T/m

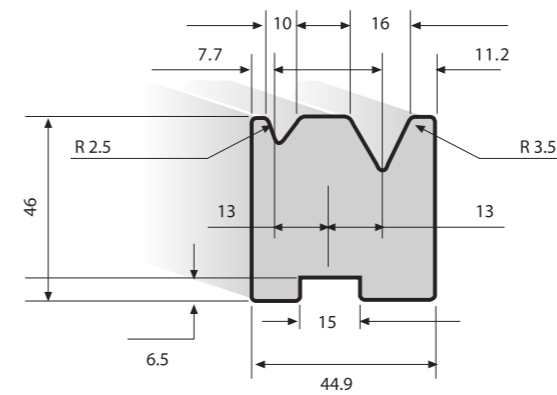

2028 / A /  $75^\circ$

24H

SOLID 50 T/m

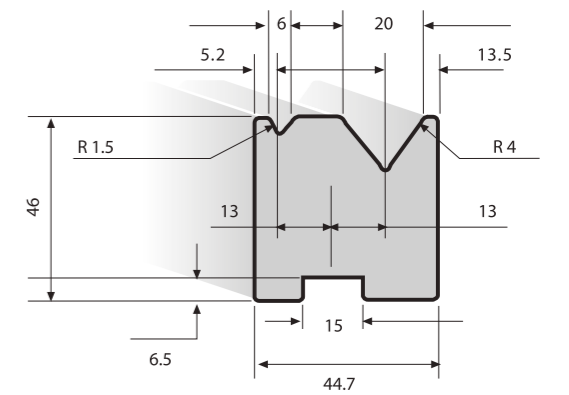

Utensili per presse piegatrici realizzati con standards di qualità superiore, temprati a induzione sulle parti di lavoro e totalmente rettificati. Lunghezza standard: 835mm; 414 mm; 835 frazionati.

Press Brake Tooling in best quality, induction hardened and ground on the working surfaces. Standard length: 835mm; 415 mm; 835 sectioned.

Abkantwerkzeuge in bester Qualität, induktionsgehärtet - arbeitsflächen geschliffen. Standardlängen: 835mm; 415 mm; 835 sektioniert.

Outils de pliage de qualité supérieure trempés par induction avec faces principales rectifiées. Longueur standard: 835mm; 415 mm; 835 fractionné.

**2029 / A / 75°**  
SOLID 50 T/m ★

24H

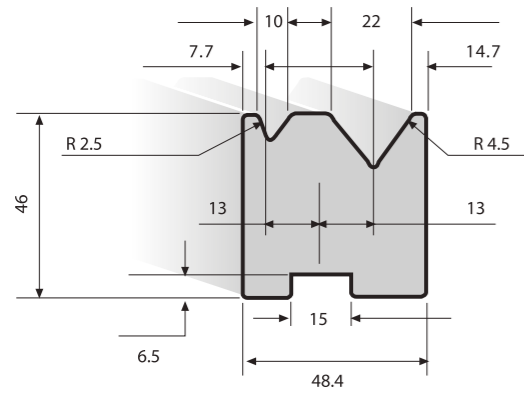

**2030 / A / 75°**  
SOLID 50 T/m ★

24H

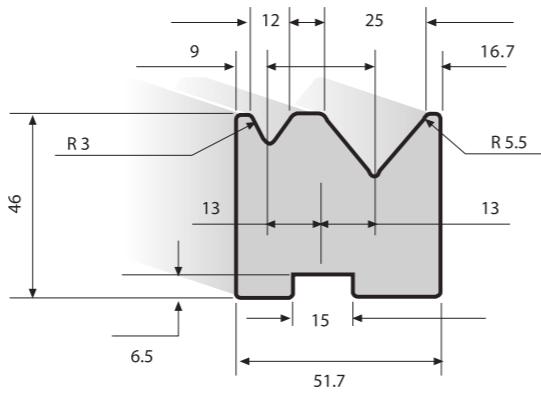

**3006**  
SOLID 100 T/m ★

6w

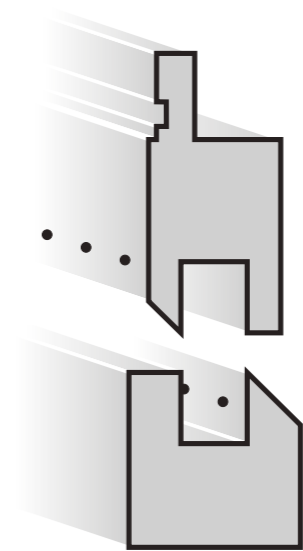

**3000**  
U= 8 mm  
U= 10 mm  
U= 12 mm  
SOLID 50 T/m ★

24H

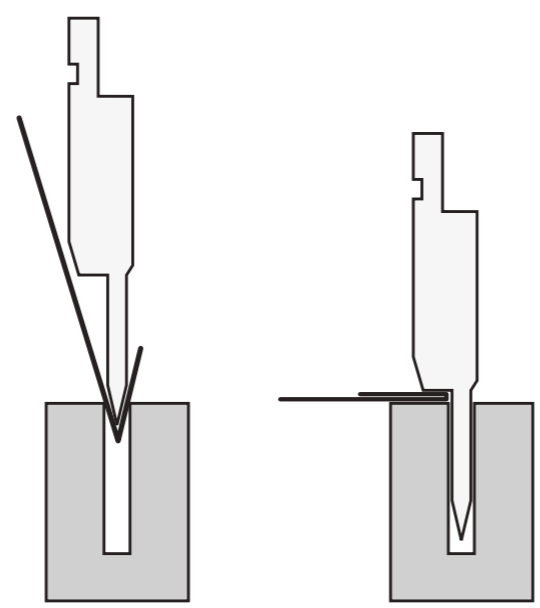
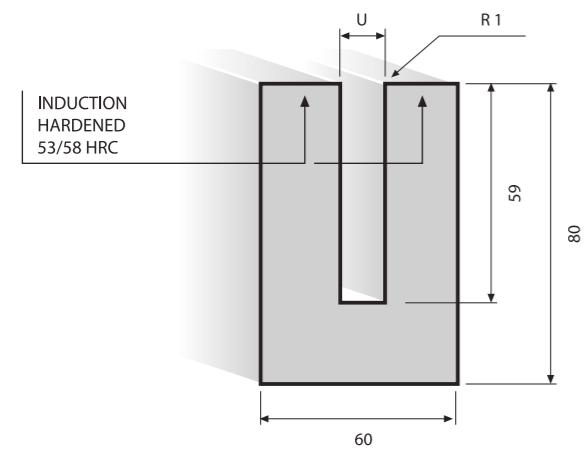

**3007**  
SOLID 100 T/m ★

6w

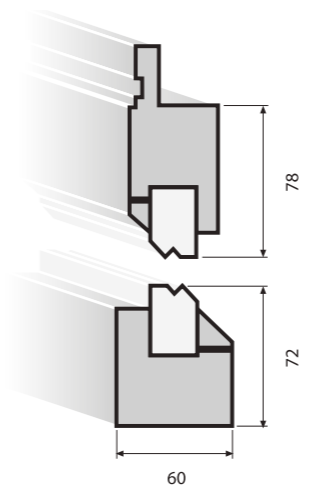

3007	Z (mm)	3007	Z (mm)
160°	1,0	90°	5,0
160°	1,5	90°	5,5
150°	2,0	90°	6,0
140°	2,5	90°	6,5
90°	3,0	90°	7,0
90°	3,5	90°	7,5
90°	4,0	90°	8,0
90°	4,5		

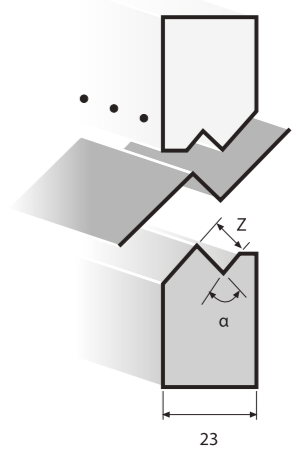

α=	160°
	150°
	140°
	90°

Utensili per presse piegatrici realizzati con standards di qualità superiore, temprati a induzione sulle parti di lavoro e totalmente rettificati. Lunghezza standard: 835mm; 414 mm; 835 frazionati.

Press Brake Tooling in best quality, induction hardened and ground on the working surfaces. Standard length: 835mm; 415 mm; 835 sectioned.

**Frazionatura standard per 835 mm - Standard sectioning for 835 mm**  
**Standard Sektionierung für 835 mm - Fractionnement standard pour 835 mm**

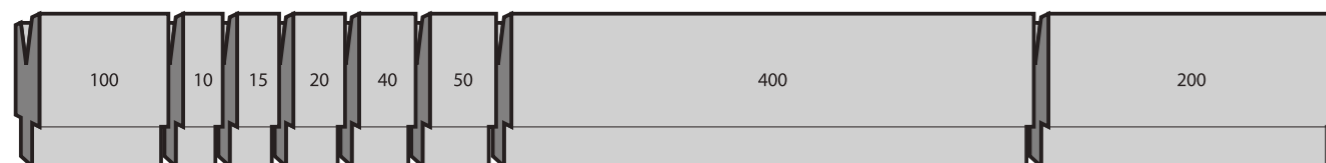

A large grid area for taking notes, consisting of a fine grid pattern on a white background, enclosed in a thin black border.



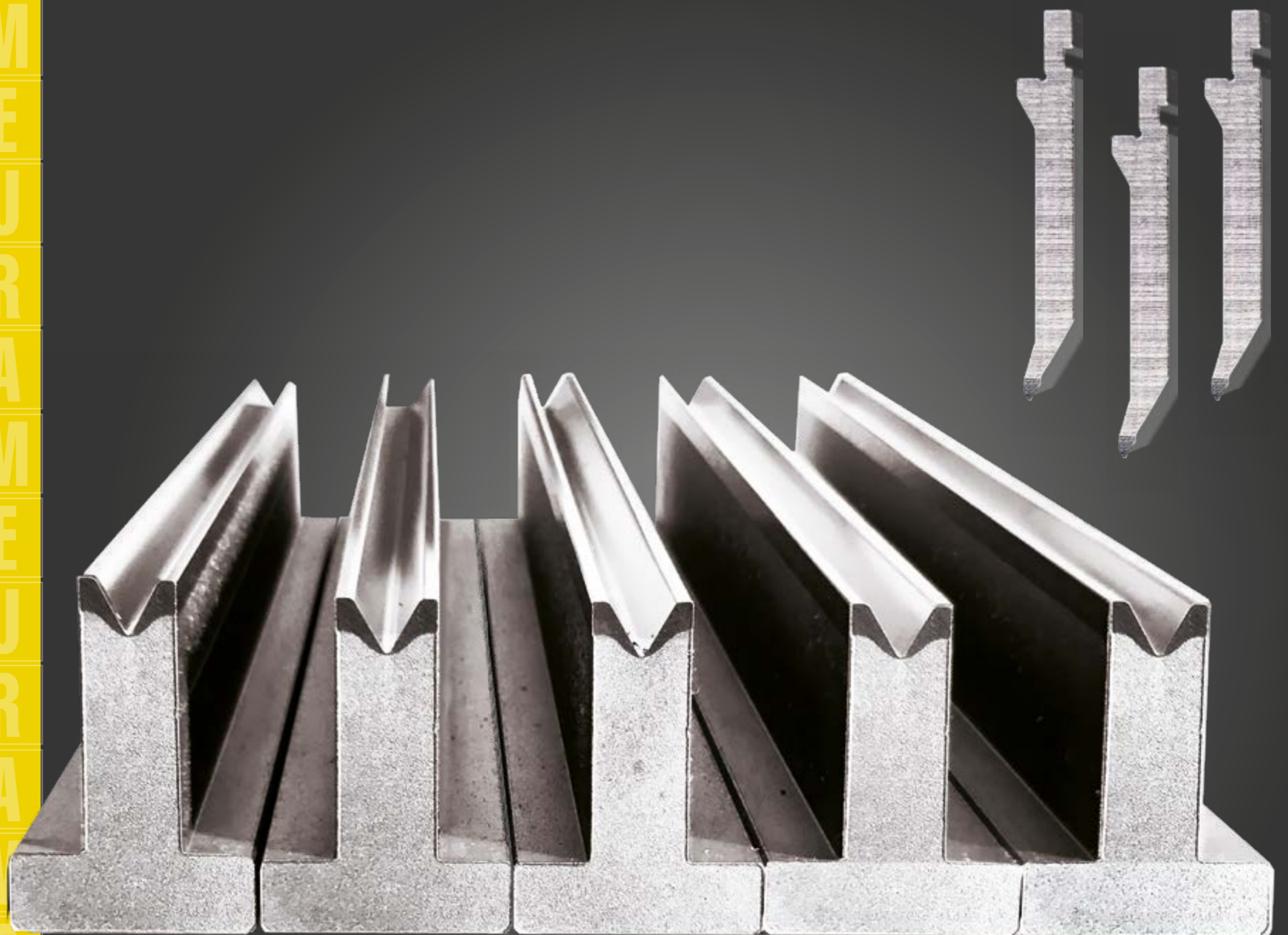
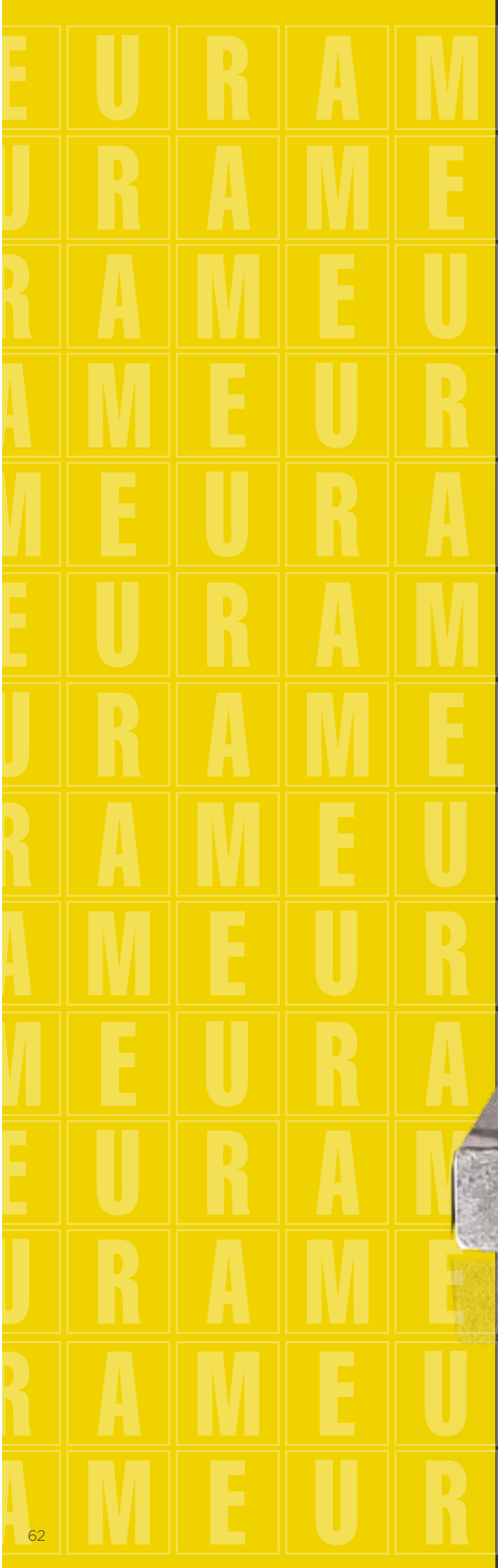

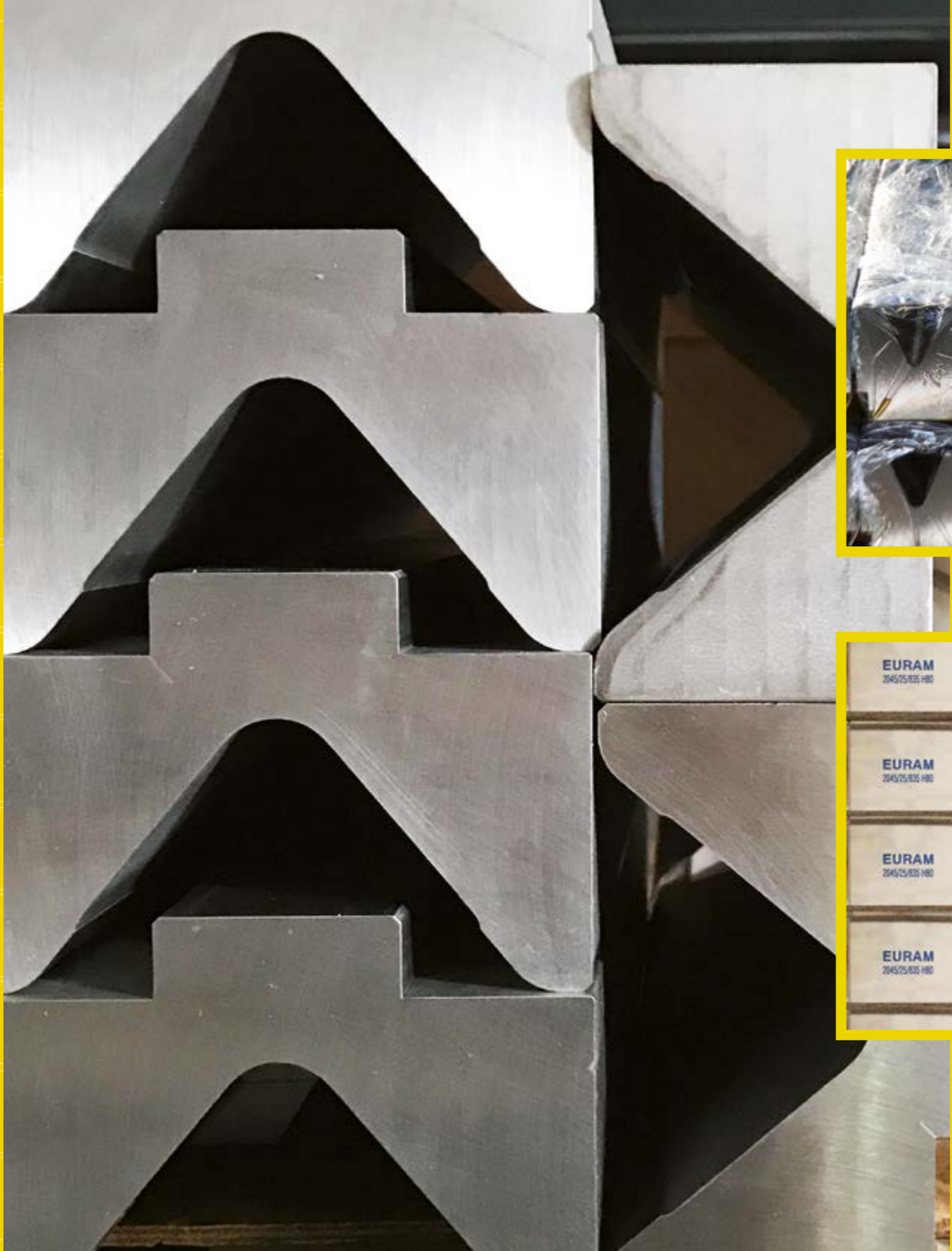
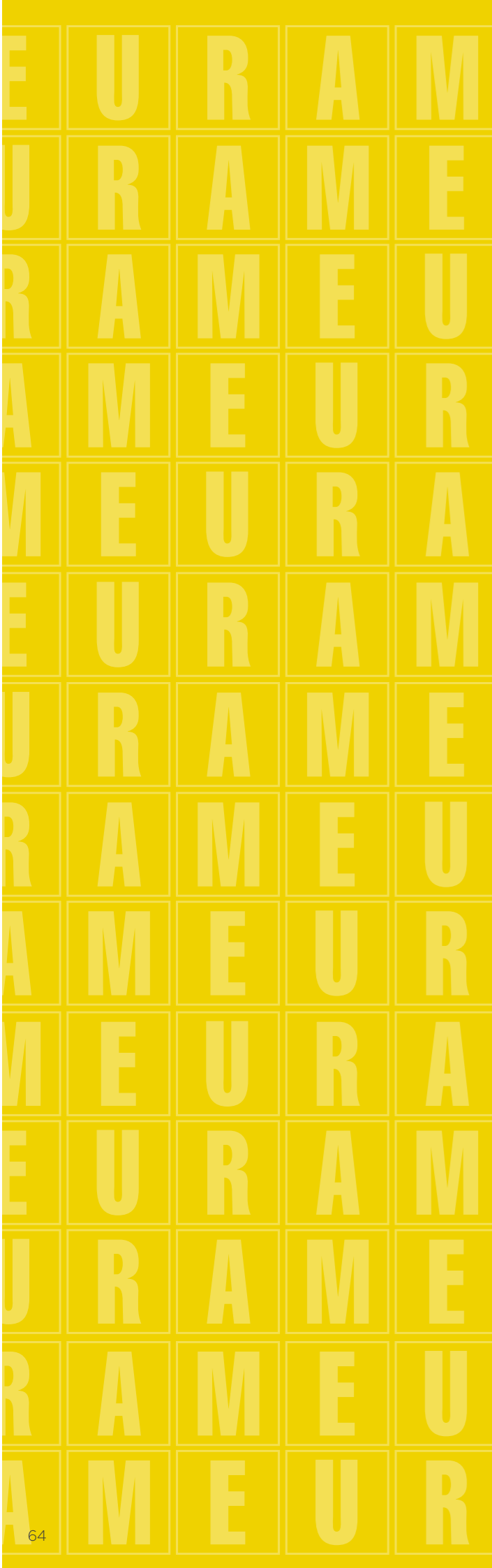

# PIEGA - SCHIACCIA HEMMING DIES



## UTENSILI PIEGA - SCHIACCIA HEMMING TOOLING

**3001 / 35° / A** 24H

V= 6 mm  
V= 8 mm

SOLID 60 T/m ★

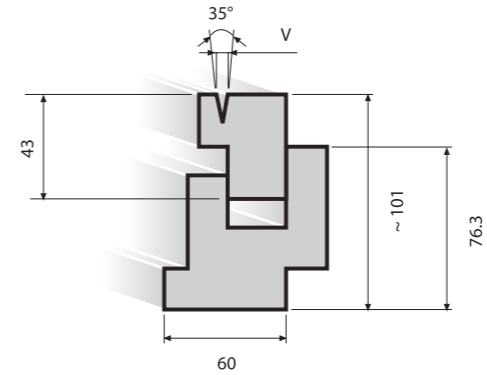

**3001 / 35° / B** 24H

V= 6 mm  
V= 8 mm

SOLID 60 T/m ★

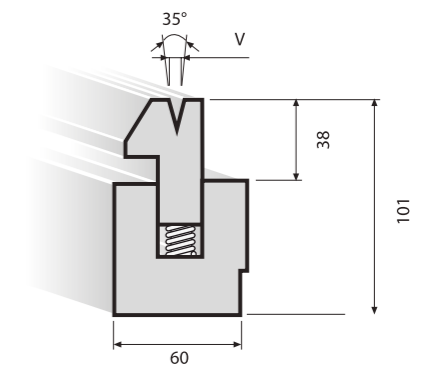

**3001 / 12 / 26°** 24H

SOLID 100 T/m ★

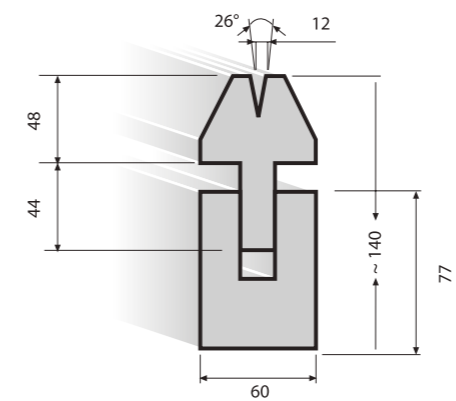

**3001** 24H

V= 10 mm / 26°  
V= 10 mm / 35°  
V= 12 mm / 35°

SOLID 100 T/m ★

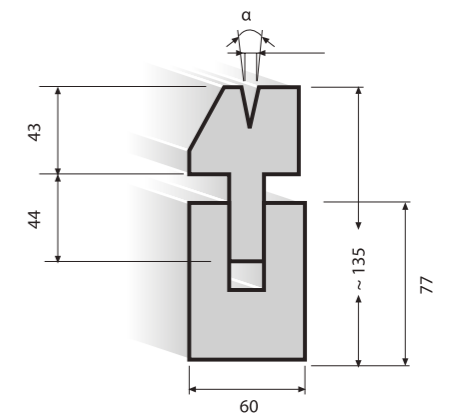

**UTENSILI PIEGA - SCHIACCIA  
HEMMING TOOLING**

**3000**  
 U= 8 mm  
 U= 10 mm  
 U= 12 mm  
 SOLID 50 T/m ★

**24H**

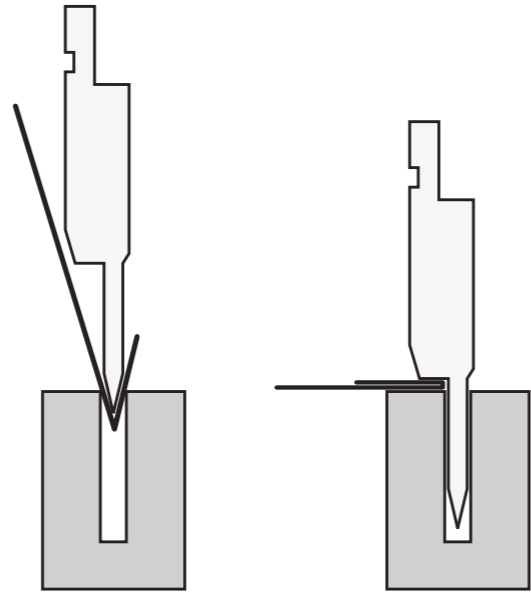
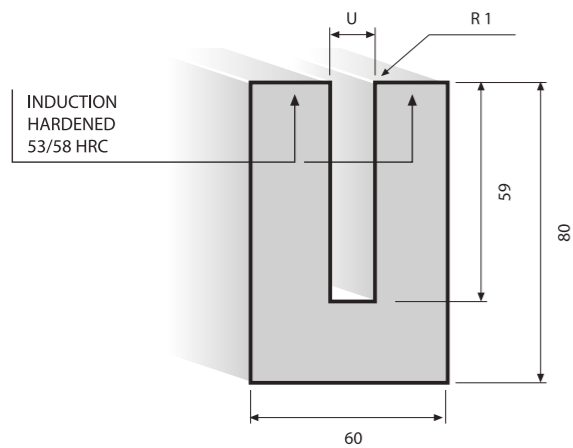

**PIEGA - SCHIACCIA PNEUMATICI  
PNEUMATIC HEMMING TOOLING**

**3001 / PN**  
 V= 10 mm / 26°  
 V= 10 mm / 35°  
 V= 12 mm / 35°  
 SOLID 100 T/m ★

**24H**

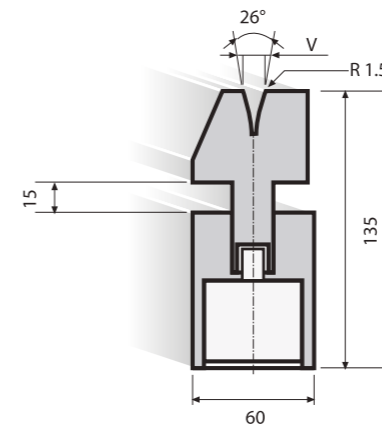

**3001 / 12 / 26° / PN**  
 SOLID 100 T/m ★

**24H**

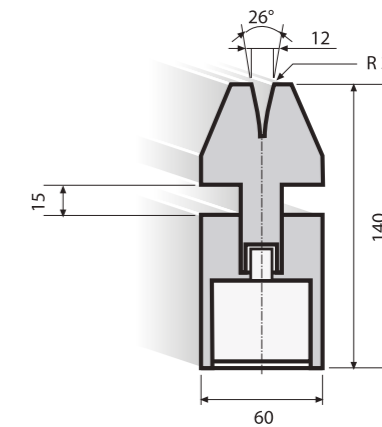

**PIEGA - SCHIACCIA PNEUMATICI  
PNEUMATIC HEMMING TOOLING**

**3001 / 8 / 30° / PN**  
 SOLID 80 T/m ★

**24H**

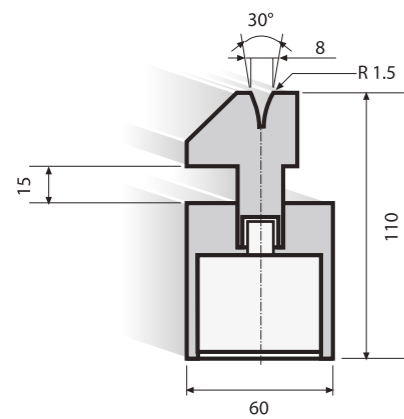

**3001 / 8 / 35° / PN**  
 SOLID 80 T/m ★

**24H**

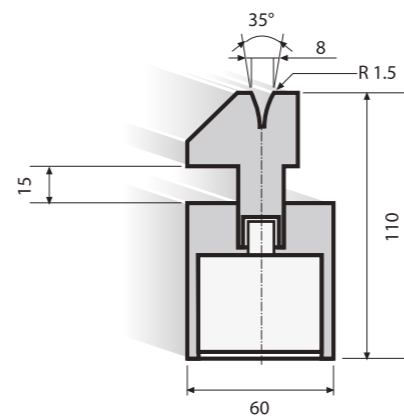

**CENTRALINA PNEUMATICA  
PNEUMATIC MOVING KIT**

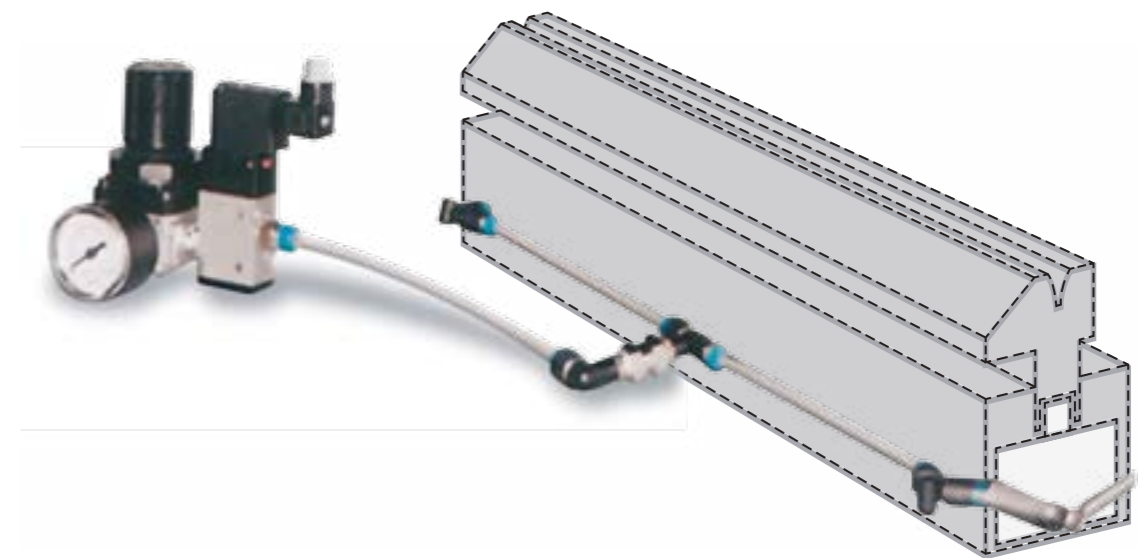

## Notes

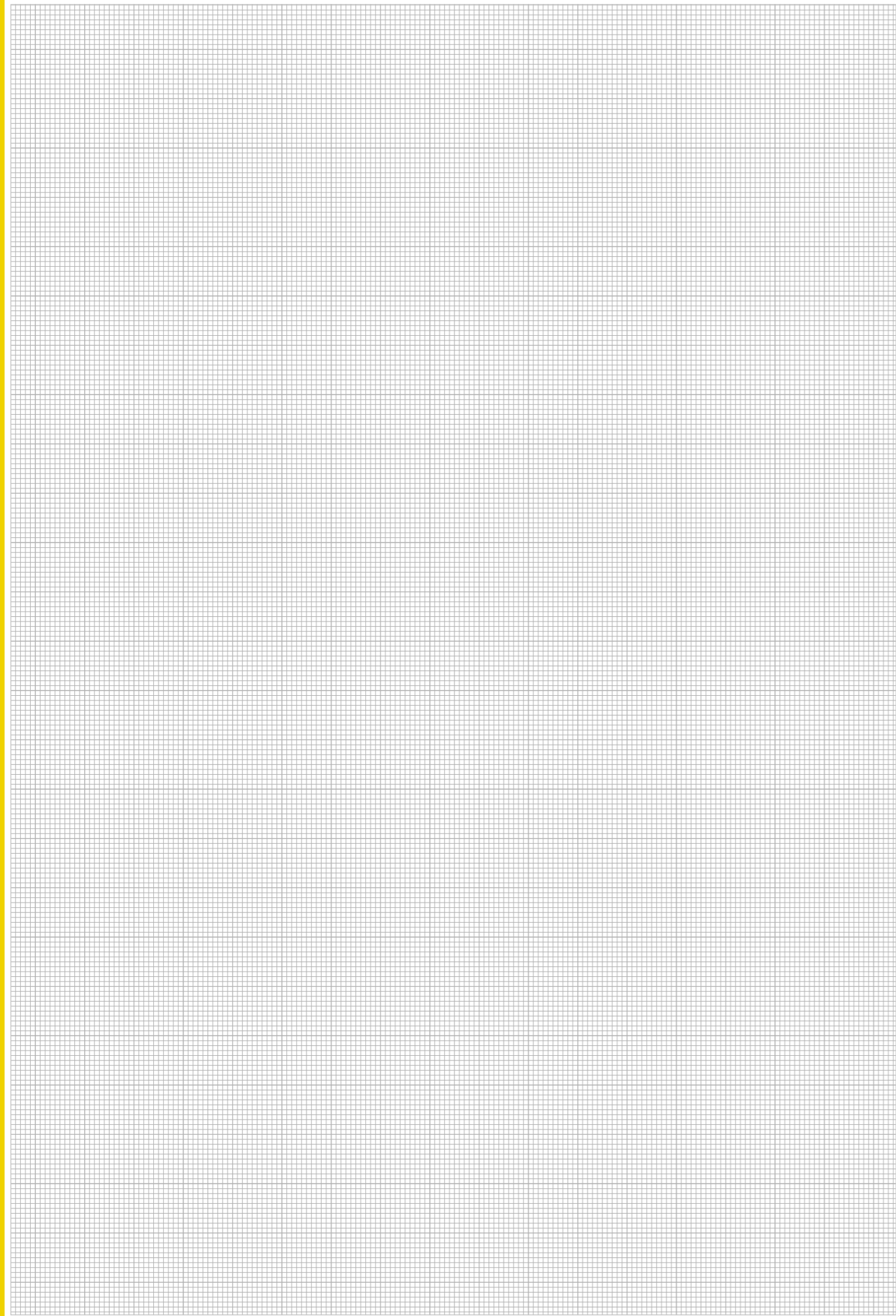

## Notes

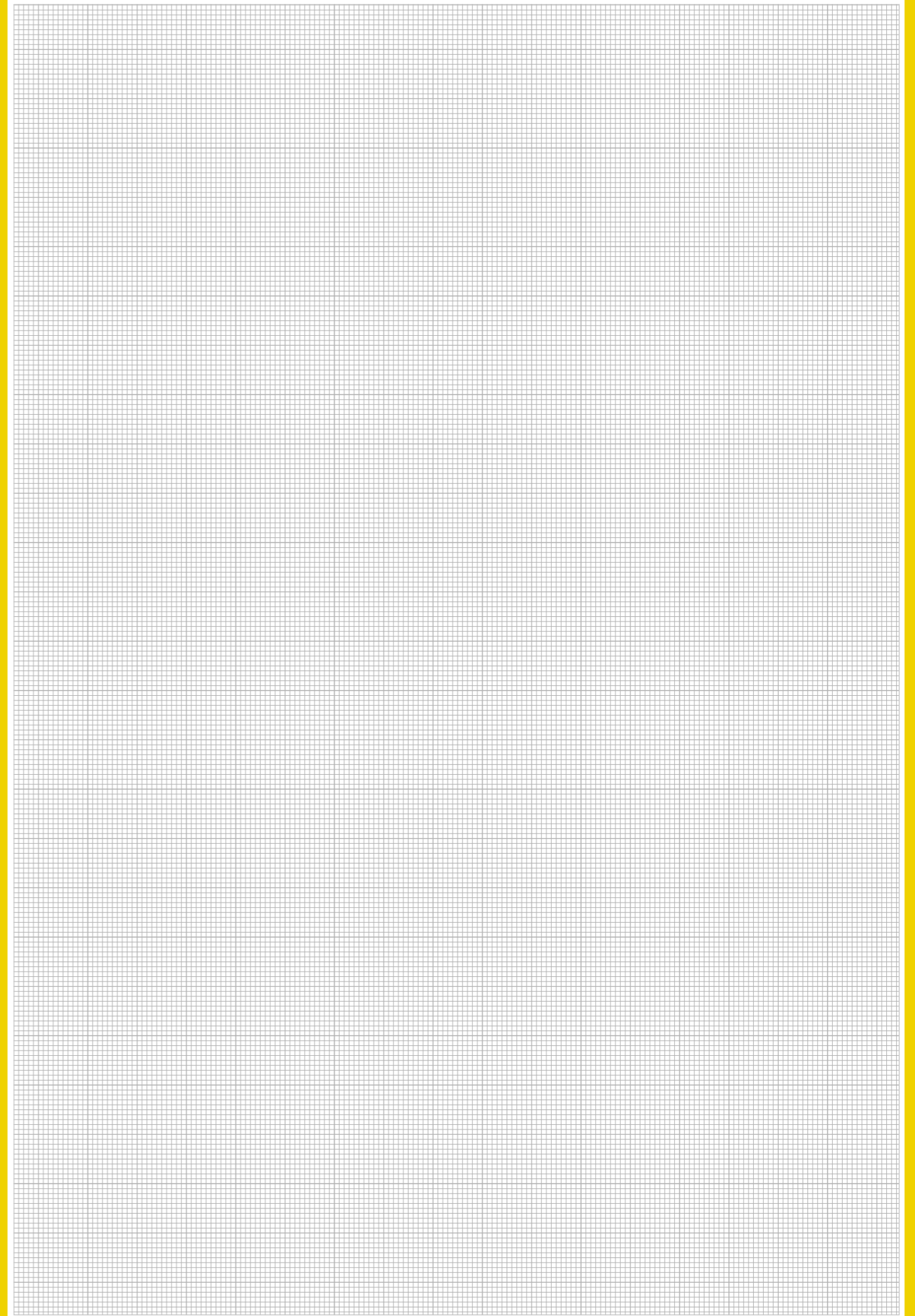

E U R A M  
J R A M E  
R A M E U  
A M E U R  
M E U R A  
E U R A M  
J R A M E  
R A M E U  
A M E U R  
M E U R A  
E U R A M  
J R A M E  
R A M E U  
A M E U R  
M E U R A  
E U R A M  
J R A M E  
R A M E U  
A M E U R



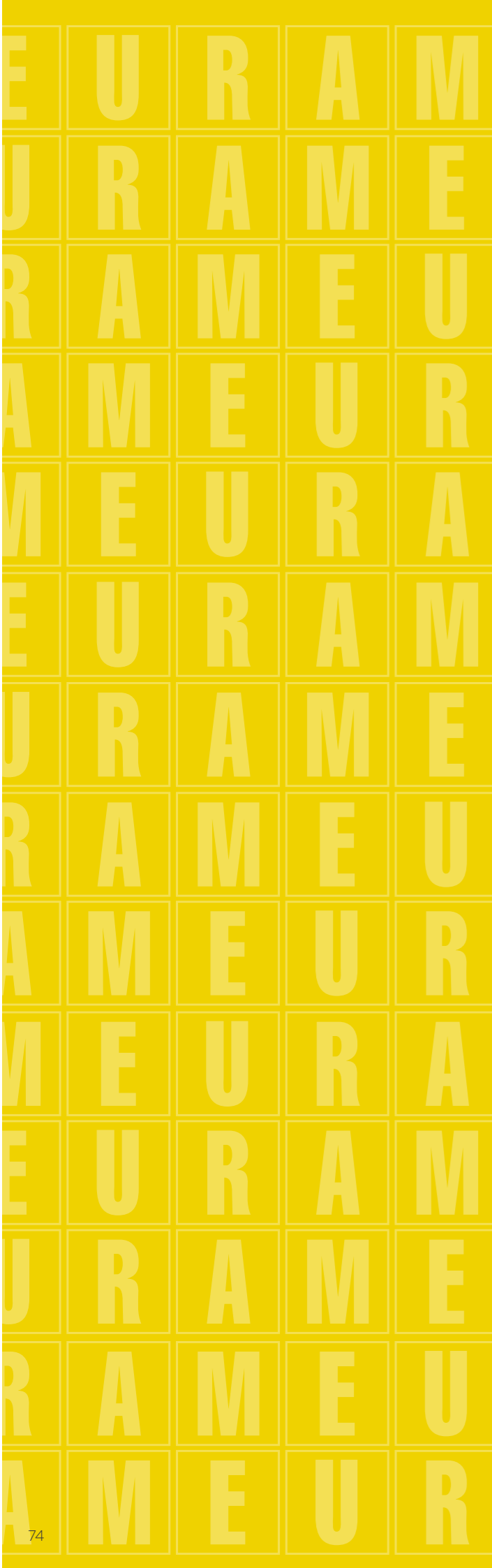

# SUPPORTI MATRICI LOWER TOOL HOLDERS

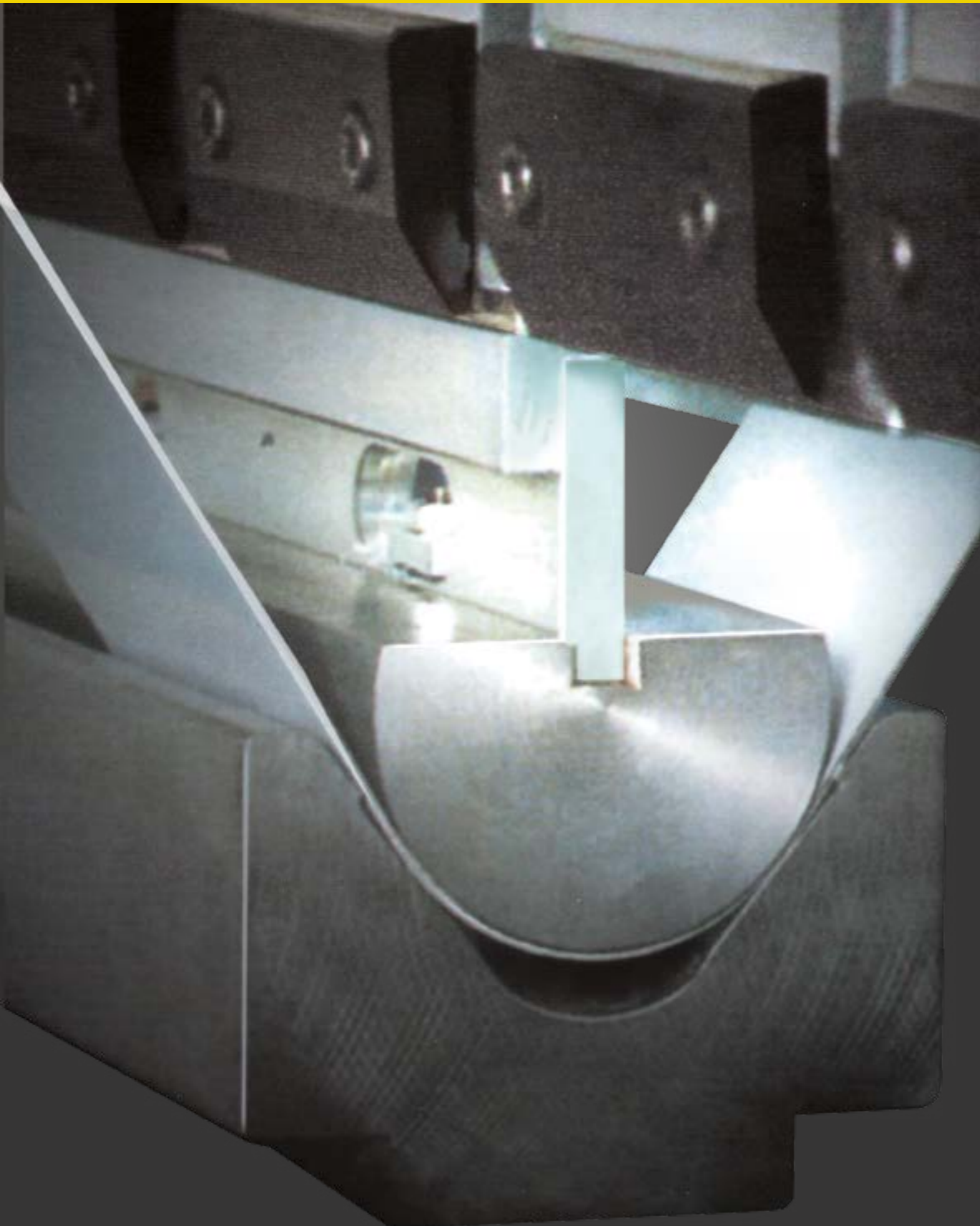

# SUPPORTI MATRICI LOWER TOOL HOLDERS

4006	
(830 mm)	H= 34 mm
(412 mm)	H= 39 mm
SOLID 100 T/m	★

24H

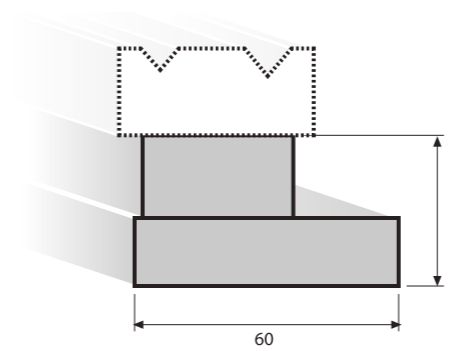

4007	
(830 mm)	H= 45 mm
(412 mm)	H= 55 mm
SOLID 100 T/m	★

24H

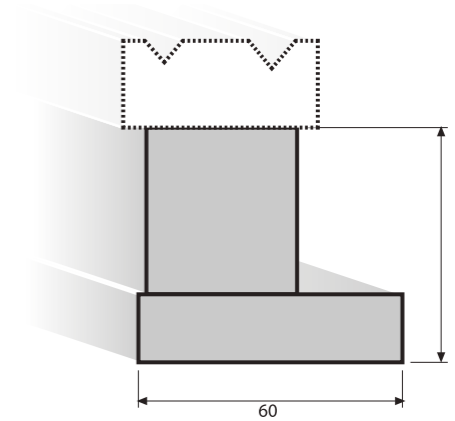

4008	
(830 mm) (412 mm)	H= 75 mm
SOLID 100 T/m	★

24H

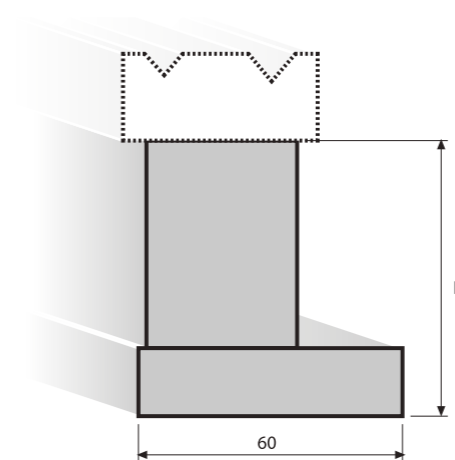

4015	
(835 mm)	
SOLID 100 T/m	★

24H

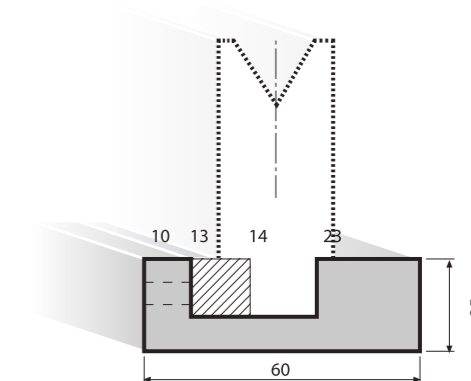



SUPPORTI MATRICI  
LOWER TOOL HOLDERS

SUPPORTI MATRICI  
LOWER TOOL HOLDERS

4017

24H

(1050 mm)  
H= 31 mm H= 61,5 mm  
SOLID 100 T/m ★

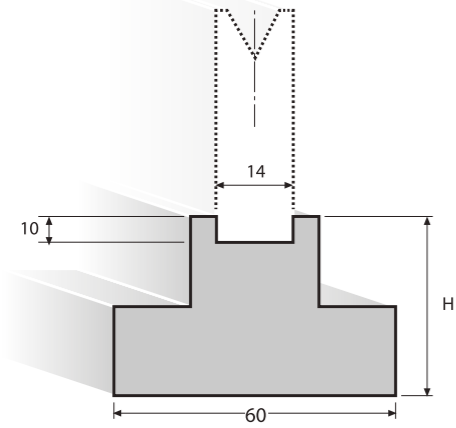

4018

24H

(835 mm)  
SOLID 100 T/m ★

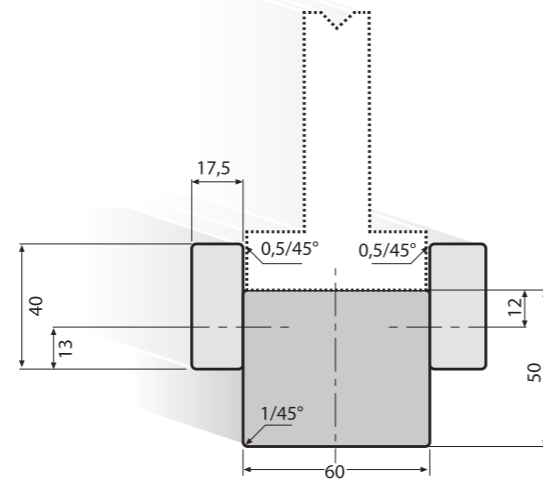

4011

24H

(835 mm)  
SOLID 100 T/m ★

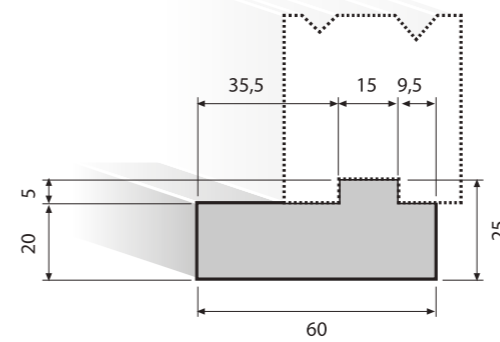

4014

6w

HYDRAULIC DIE OLDER  
( TRUMPF, LVD, HACO, BEYELER,  
AMERICAN, ETC.)

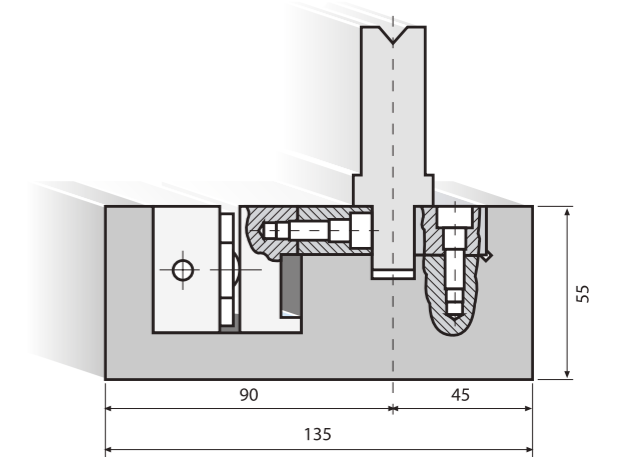

4016

24H

(1050 mm)  
SOLID 100 T/m ★

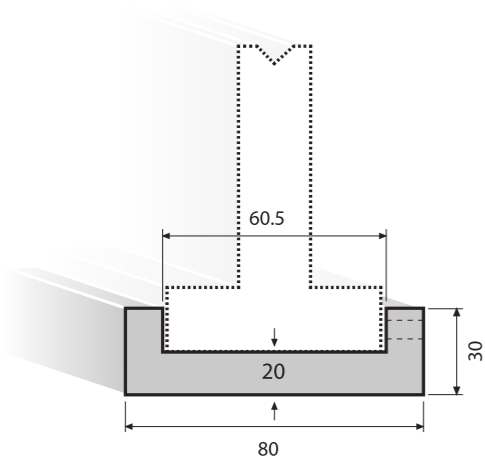

4010

24H

(835 mm)  
SOLID 100 T/m ★

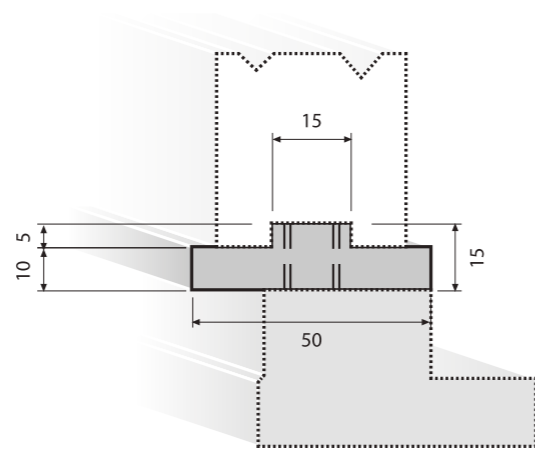

4014 / A

6w

HYDRAULIC DIE HOLDER (AMADA)  
★

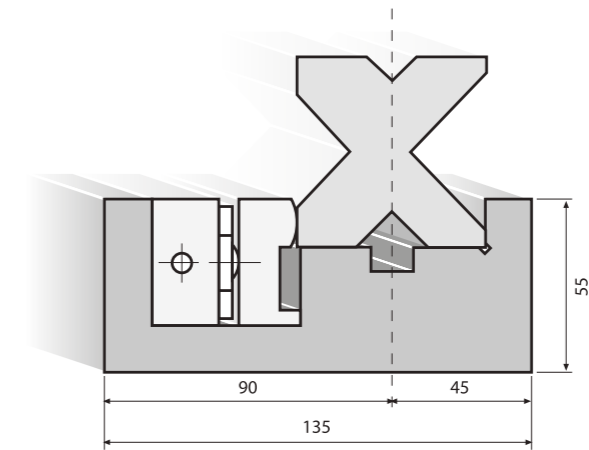

## Notes

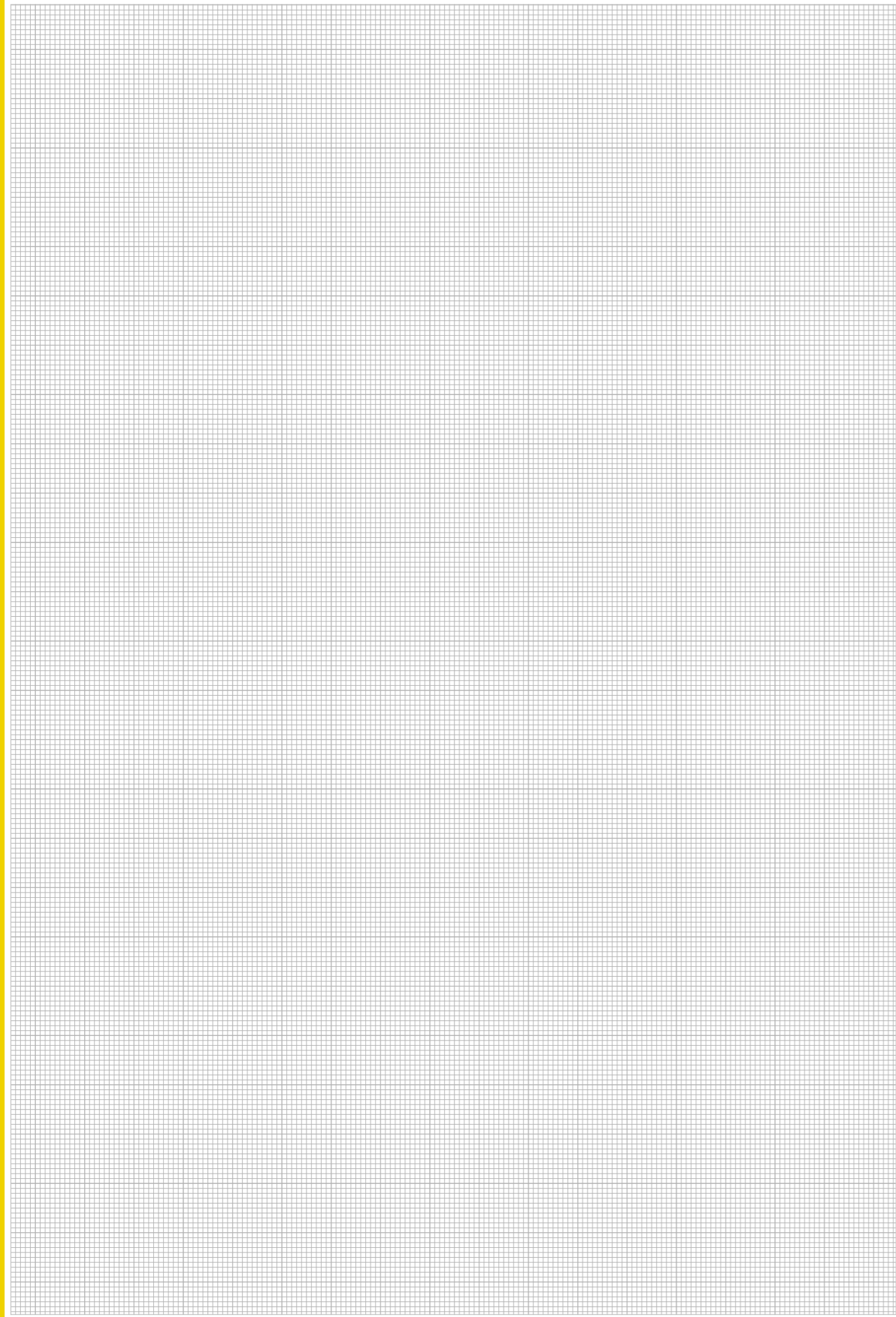

## Notes

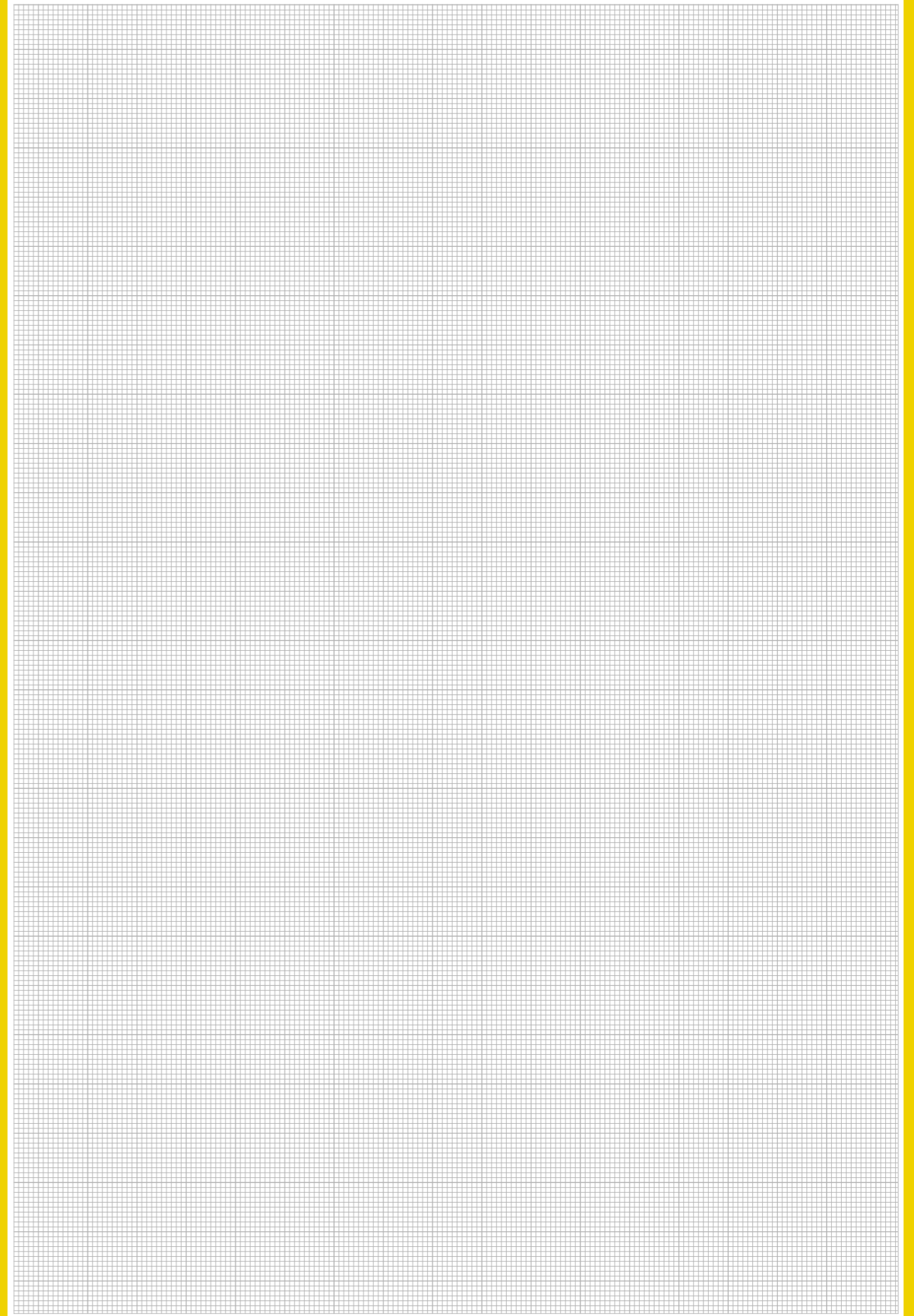

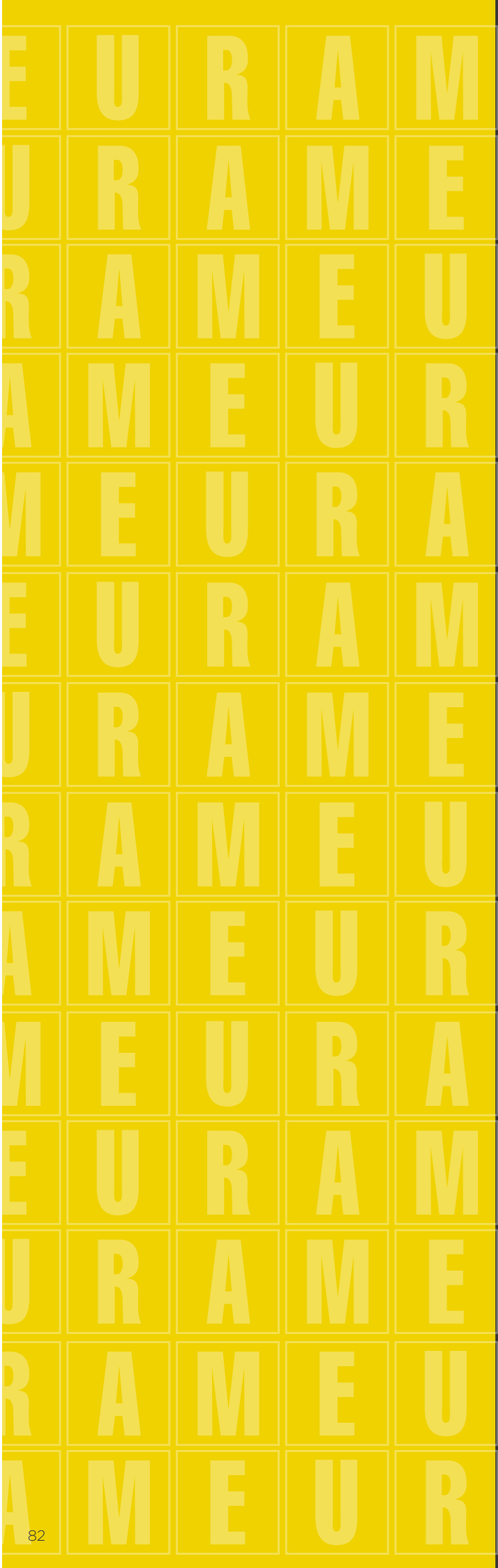

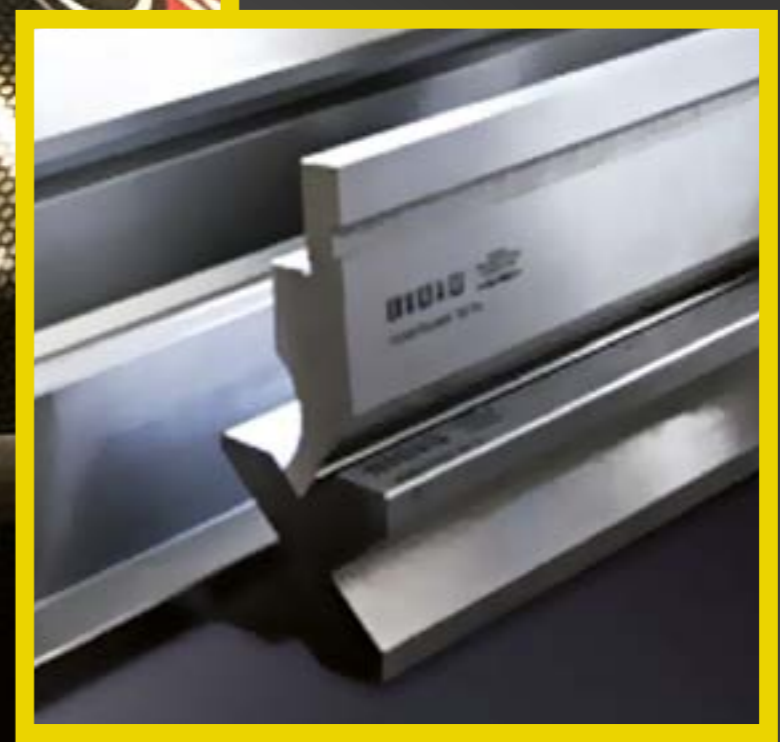
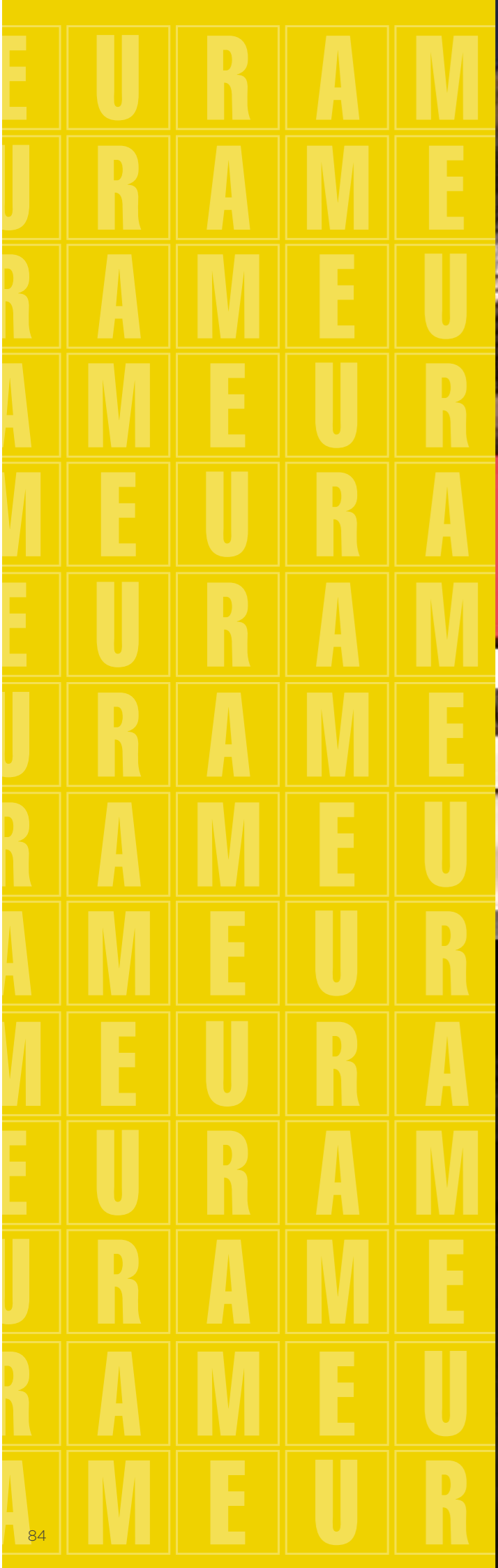

# INTERMEDIARI SUPPORTO PUNZONI INTERMEDIATE UPPER TOOL HOLDERS



## INTERMEDIARI SUPPORTO PUNZONI INTERMEDIATE UPPER TOOL HOLDERS

### INT. 1 / STD

L= 150 mm  
H= 100 mm



24H

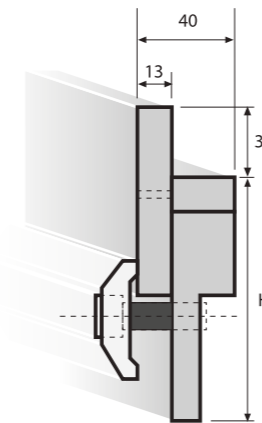

### INT. 1 SECURITY

L= 150 mm  
H= 100 mm



24H

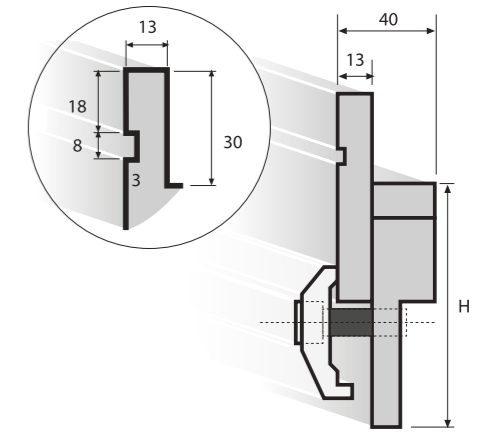

### INT. 1 SECURITY TALL

L= 150 mm  
H= 150 mm



24H

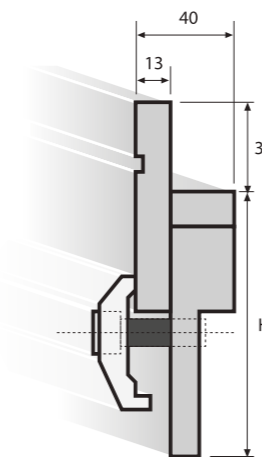

### INT. 1 SEC / 120

L= 150 mm  
H= 120 mm



24H

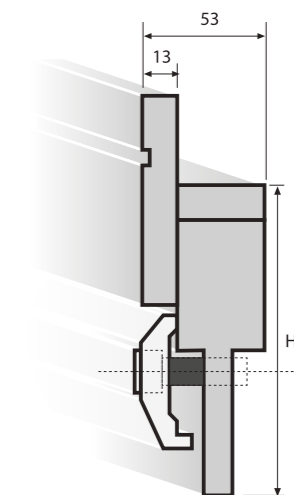

**INT. 1 SEC / 160**

24H

L= 150 mm  
H= 160 mm

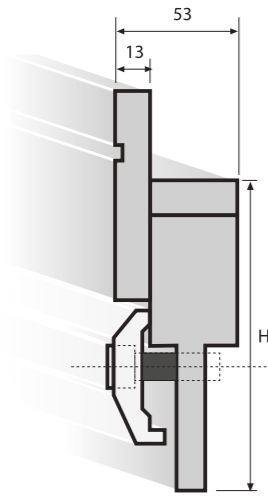

**INT. 2**

24H

L= 150 mm  
BEYELER EURO

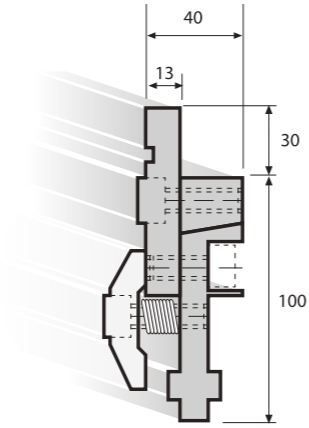

**INT. 4**

6w

BEYELER S - AMADA  
H= 67 mm  
L= 150 mm

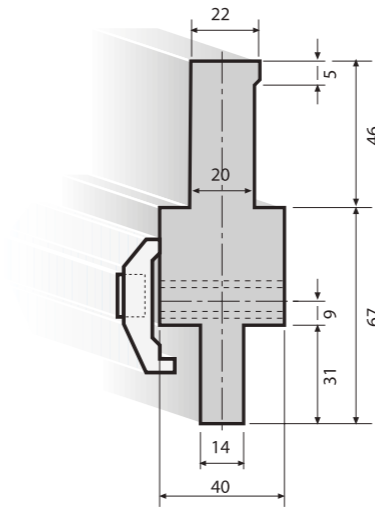

**INT. 5**

6w

LVD - HACO - AMERICAN - AMADA  
H= 80 mm  
L= 150 mm

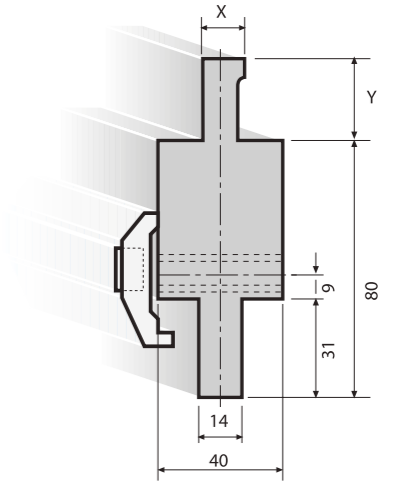

**INT. AM**

24H

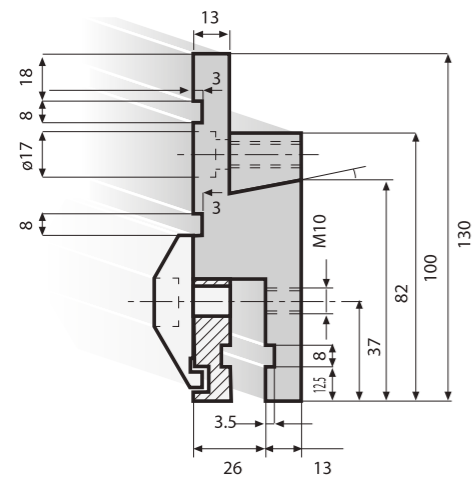

**INT. 3**

6w

BEYELER R - AMADA  
H= 67 mm  
L= 150 mm

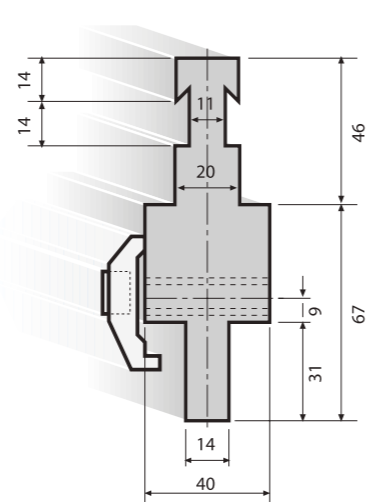

**INT. 6**

6w

TRUMPF - AMADA  
H= 80 mm  
L= 150 mm

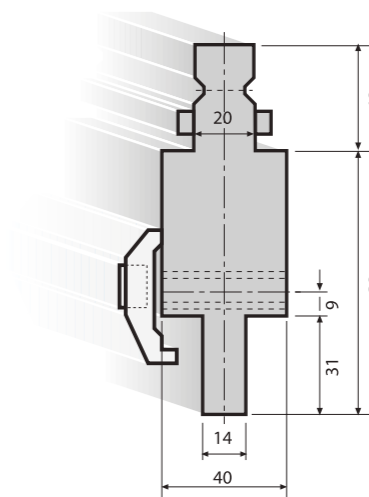

**STAFFA DI SICUREZZA  
SECURITY CLAMP**

24h

**Staffa di sicurezza a chiusura manuale rapida**

Quick release security clamp

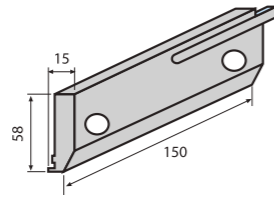

**Con bloccaggio rinforzato di Adiprene per utensili frazionati**

With Adiprene rubber blocking from segmented tooling

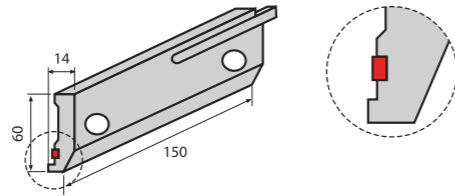

**Staffa di sicurezza**

Security clamp

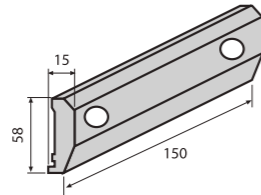

**Con bloccaggio rinforzato di Adiprene per utensili frazionati**

With Adiprene rubber blocking from segmented tooling

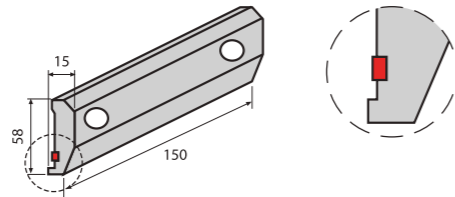

**Staffa standard**  
Std. clamp

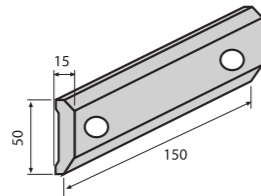

**KIT PER DOPPIO STAFFAGGIO DI SICUREZZA**  
EQUIPMENT FOR DOUBLE SAFETY CLAMPING

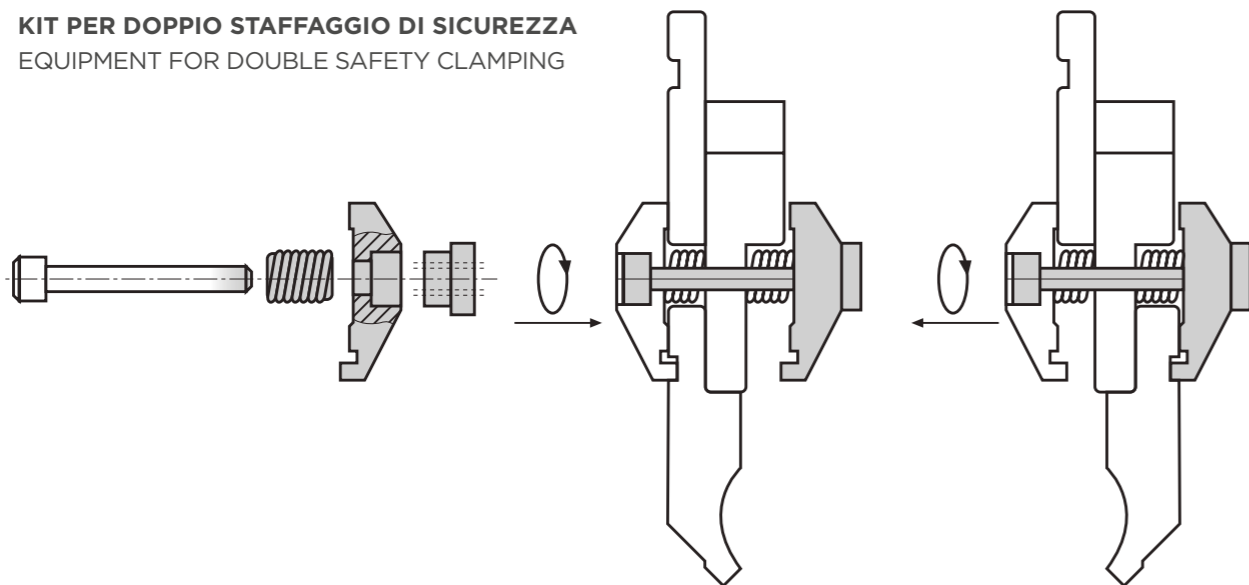

**STAFFA IDRAULICA A BLOCCAGGIO RAPIDO  
HYDRA FAST CLAMP**

PRESSIONE IDRAULICA MAX 200 BAR  
HYDRAULIC PRESSURE MAX 200 BAR

NOW

6w

AT SOONEST

24h

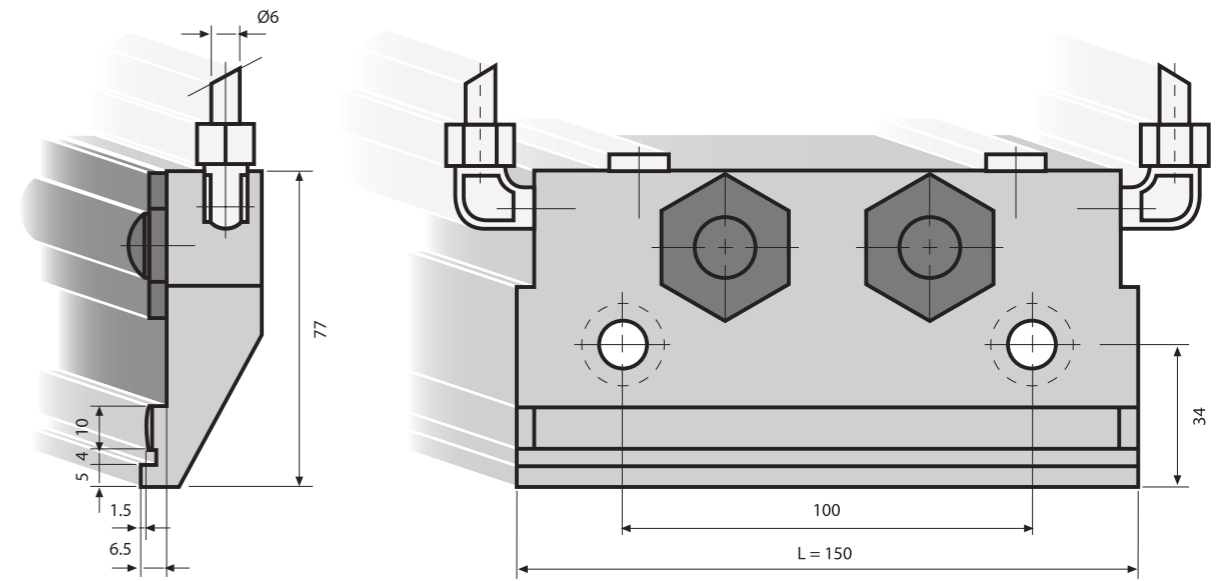

**INT. HYDRA**

INTERMEDIARIO IDRAULICO  
HYDRAULIC PUNCH HOLDER  
AMADA SYSTEM

NOW

6w

AT SOONEST

24h

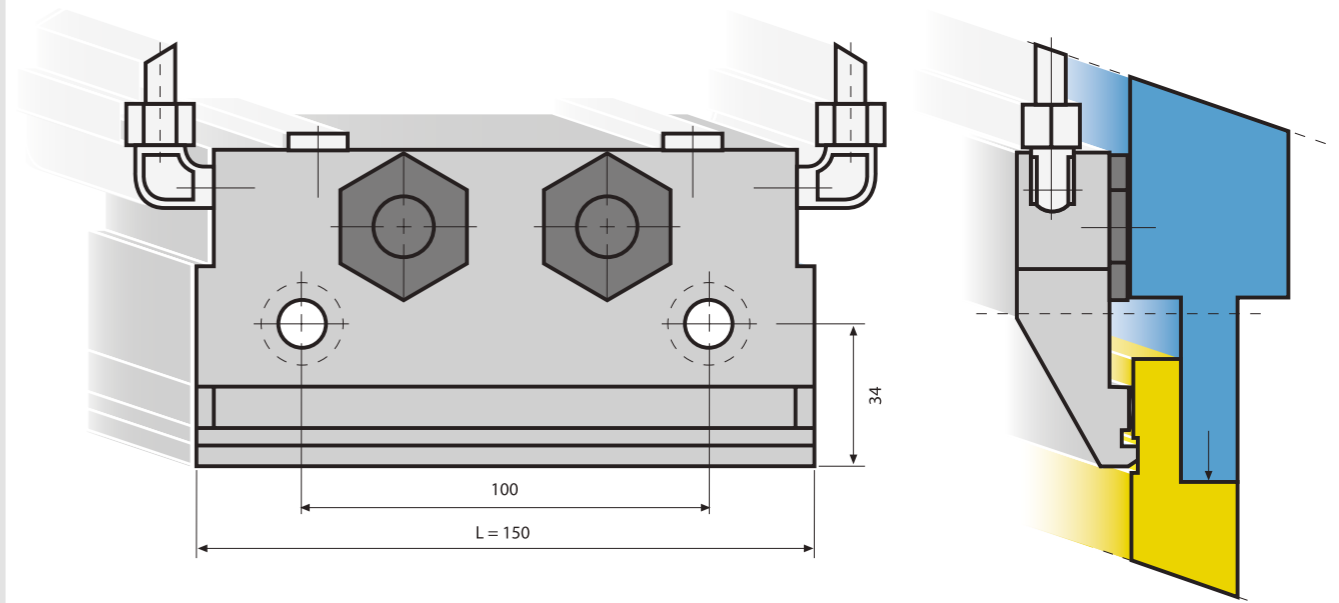

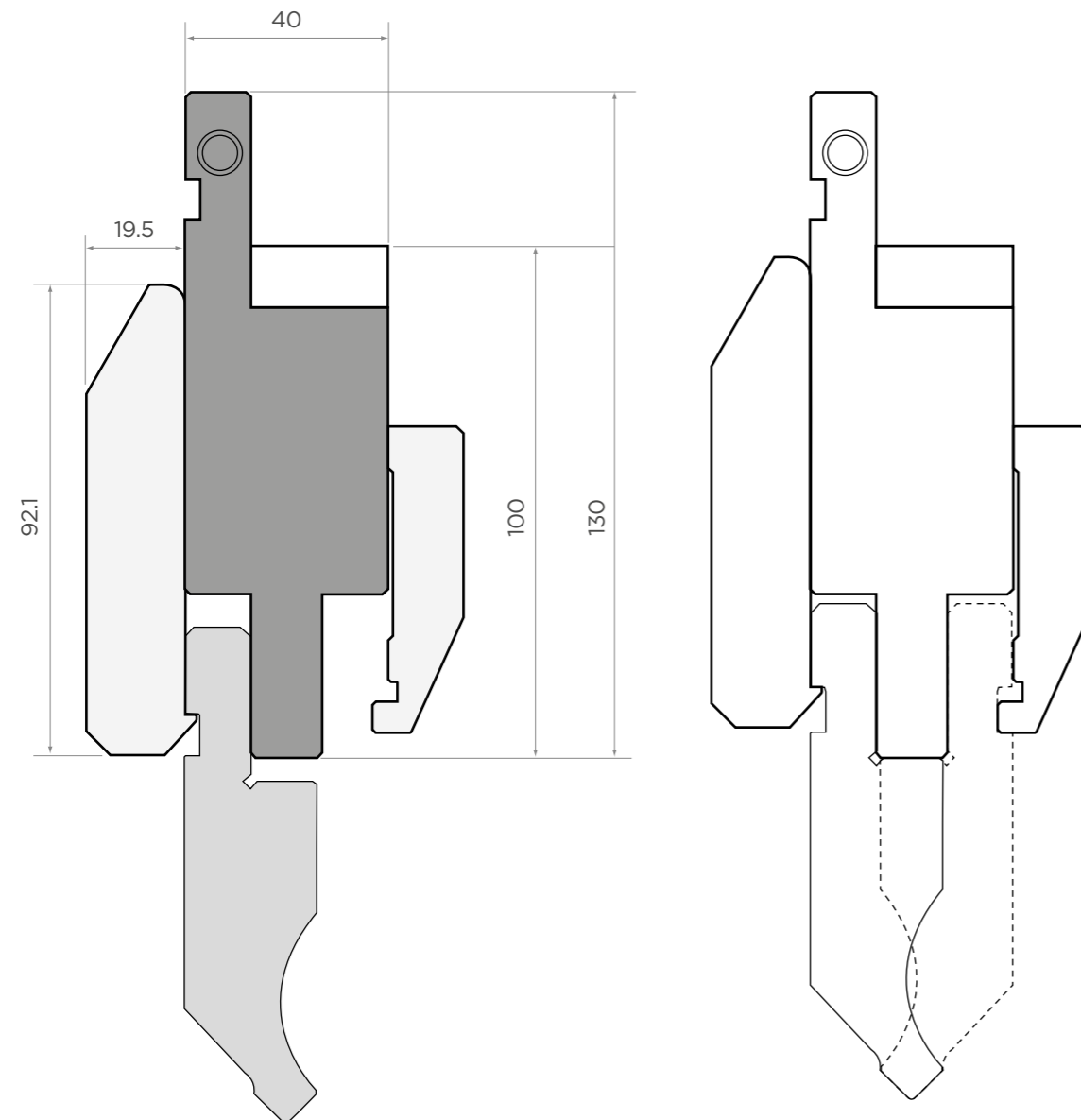

- L'inserimento e il disimpegno della lama può avvenire frontalmente senza alcuna modifica del codolo.
- Richiamo in battuta automatico.
- Cuneo di regolazione.
- Staffa posteriore regolabile anteriormente per il serraggio manuale.

- Punch installing and disinstalling from the front without fitting modification.
- Automatic working set-up of the punch.
- Movable wedge.
- Security back clamp adjustable from the front by manual blocking.

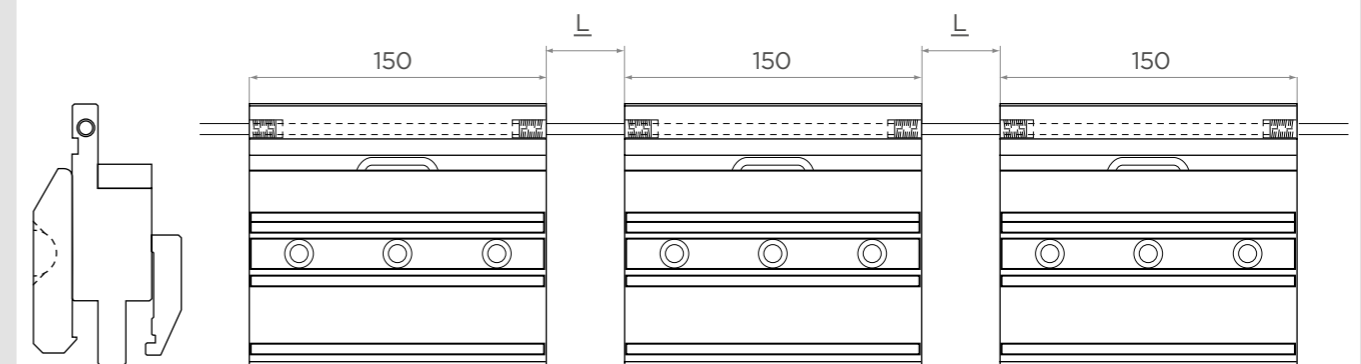



## Notes

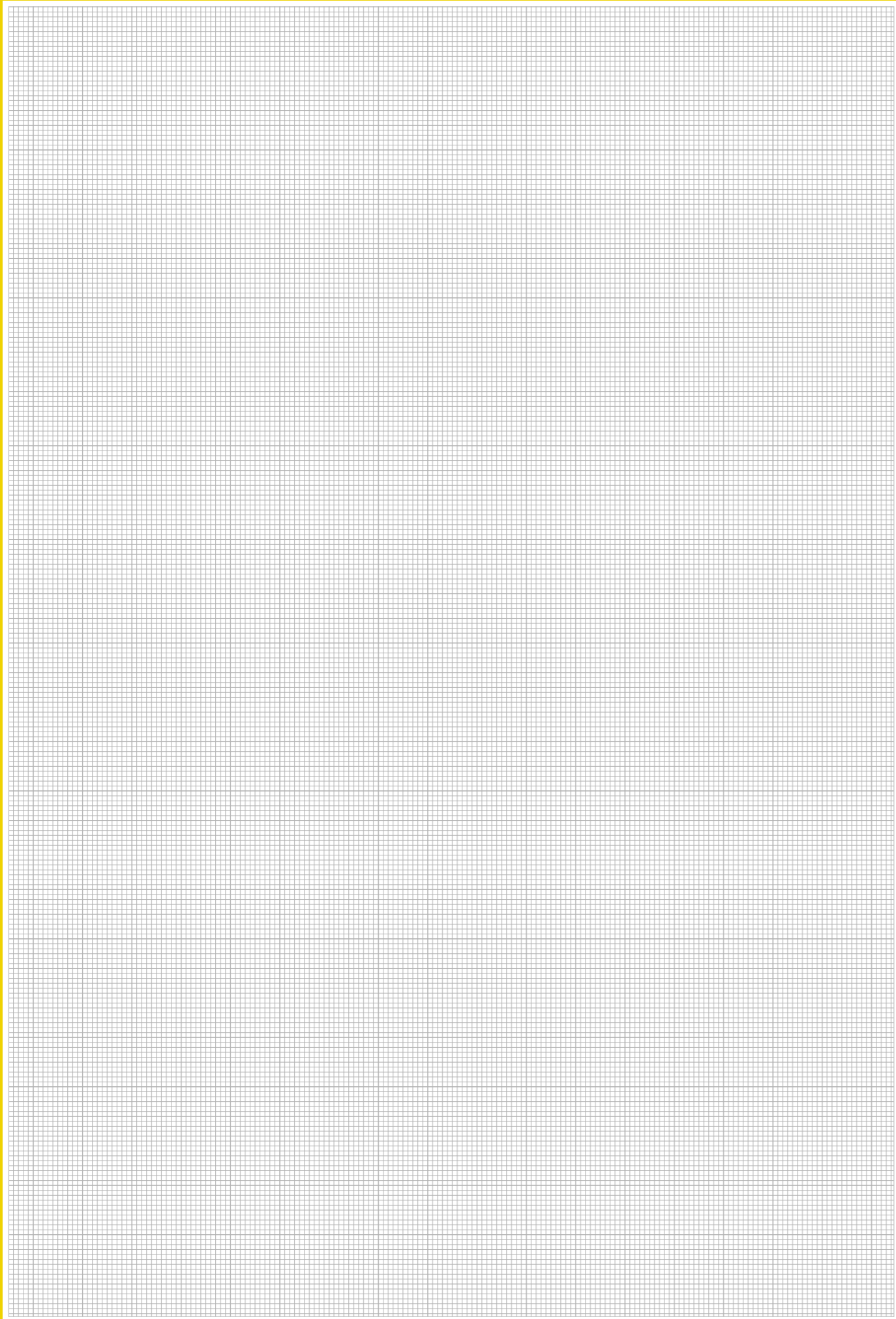

## Notes

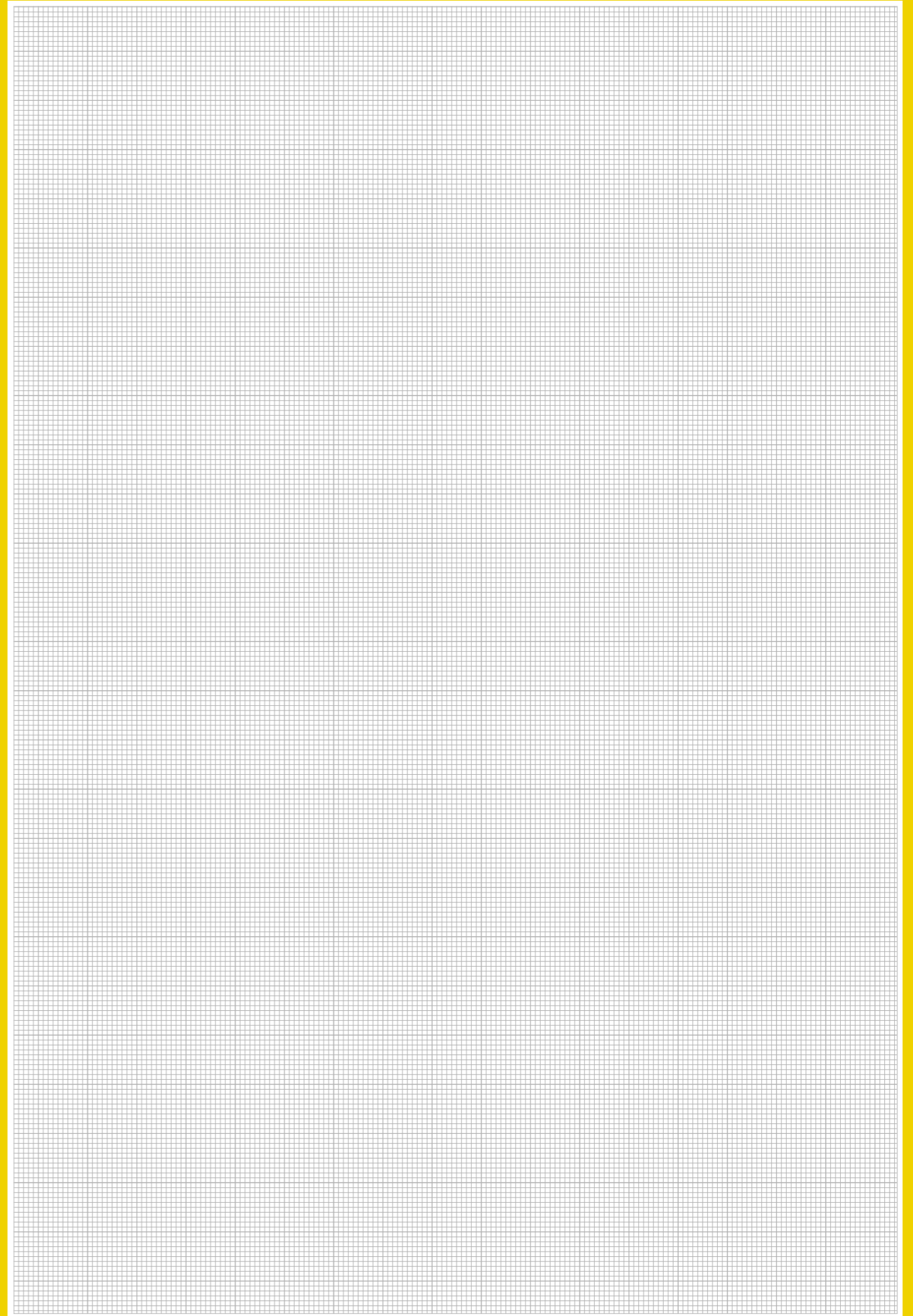

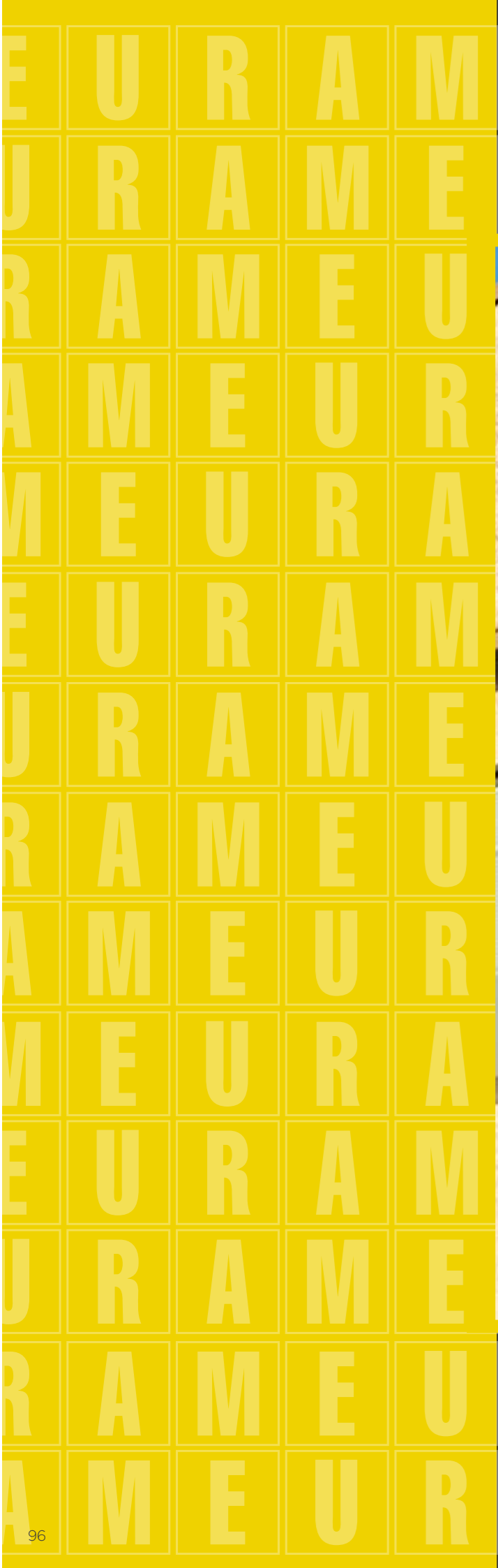



**E U R A M**

WORLD WIDE EURAM



TEMPRATURA AD INDUZIONE  
INDUCTION HARDENING

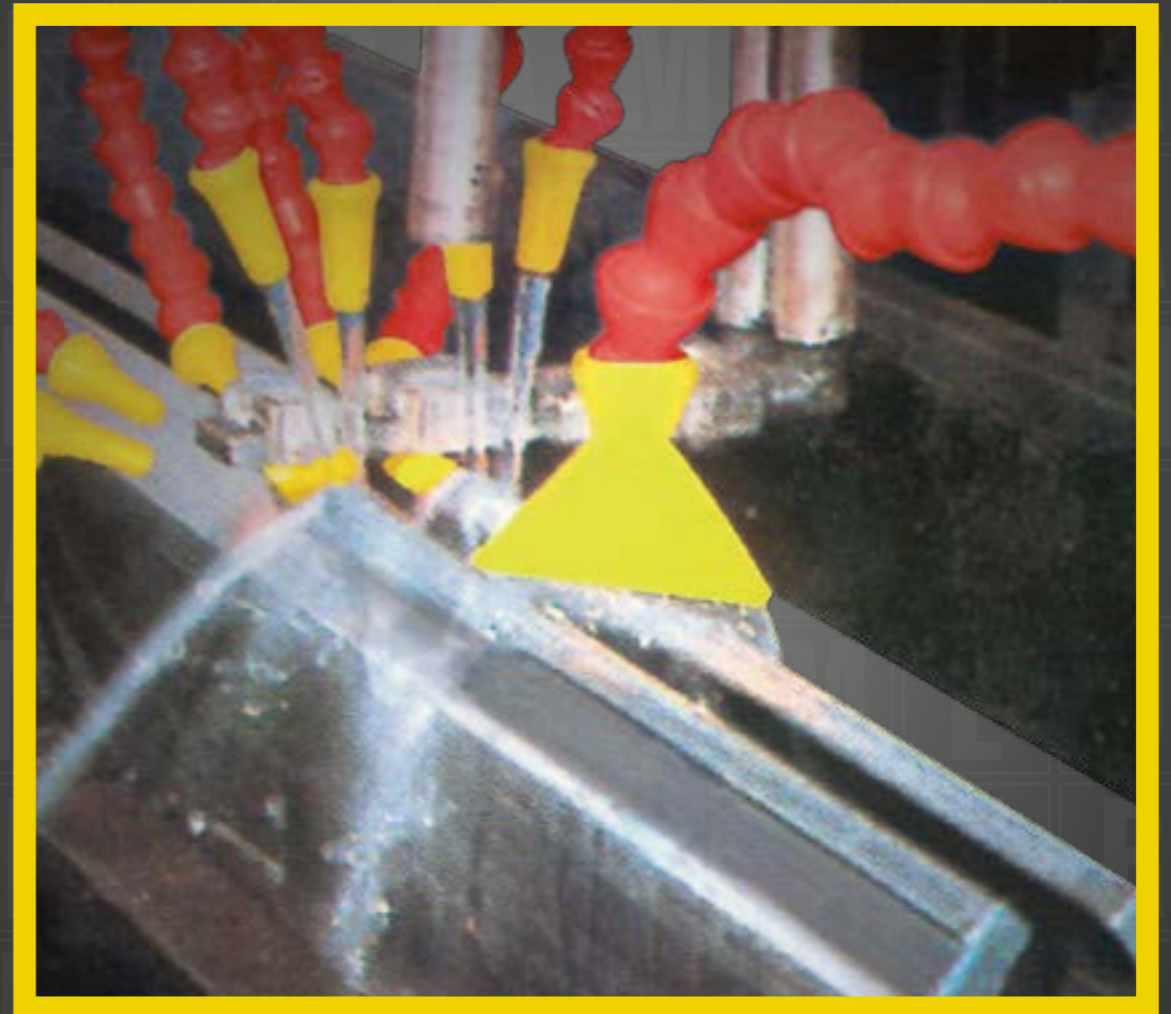

**1310 / T / 86° / R1**

SOLID 100 T/m ★★

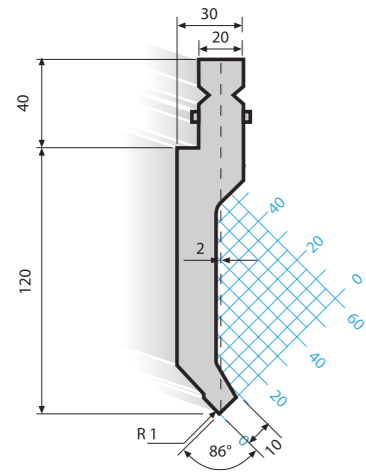

NOW

6w

AT SOONEST

24h

**1311 / T / 86° / R1**

SOLID 100 T/m ★★

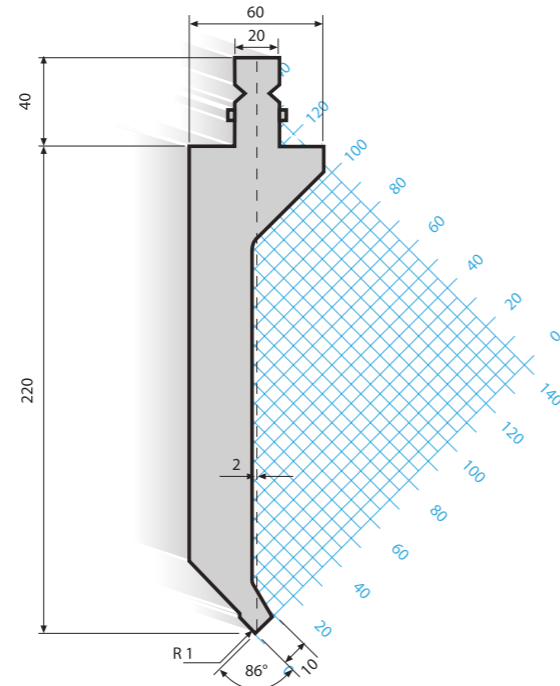

NOW

6w

AT SOONEST

24h

**1316 / T / 60° / R4**

SOLID 130 T/m ★★

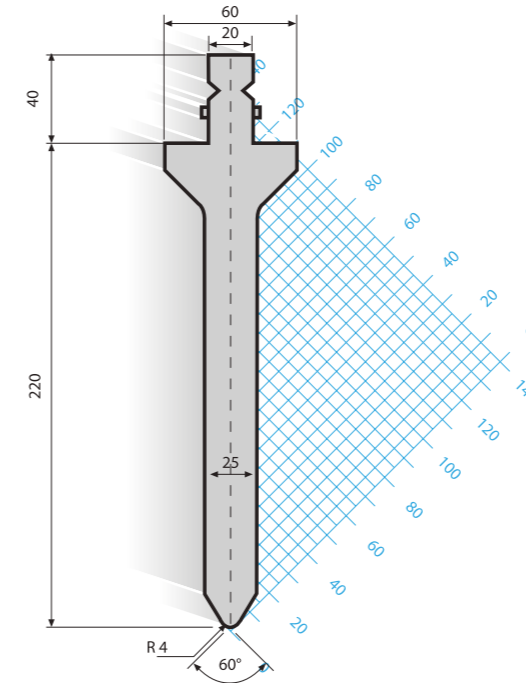

NOW

6w

AT SOONEST

24h

**1317 / T / 26° / R1**

SOLID 100 T/m ★★

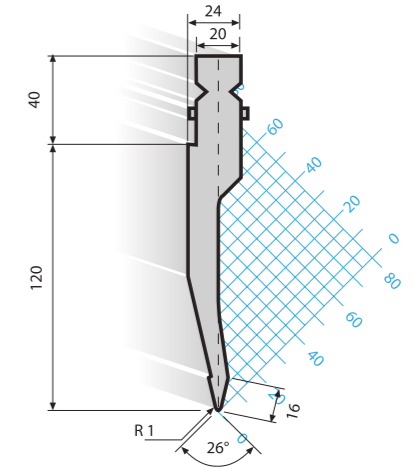

NOW

6w

AT SOONEST

24h

**1312 / T / 86° / R1**

SOLID 100 T/m ★★

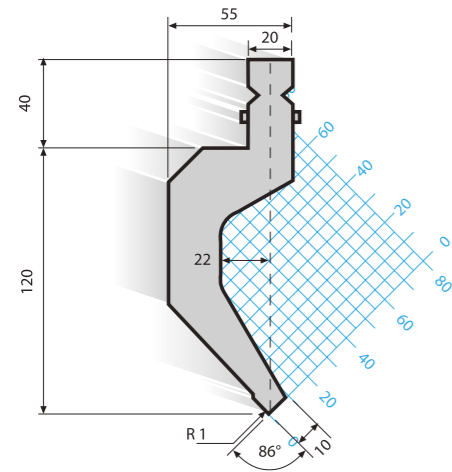

NOW

6w

AT SOONEST

24h

**1313 / T / 86° / R1**

SOLID 100 T/m ★★

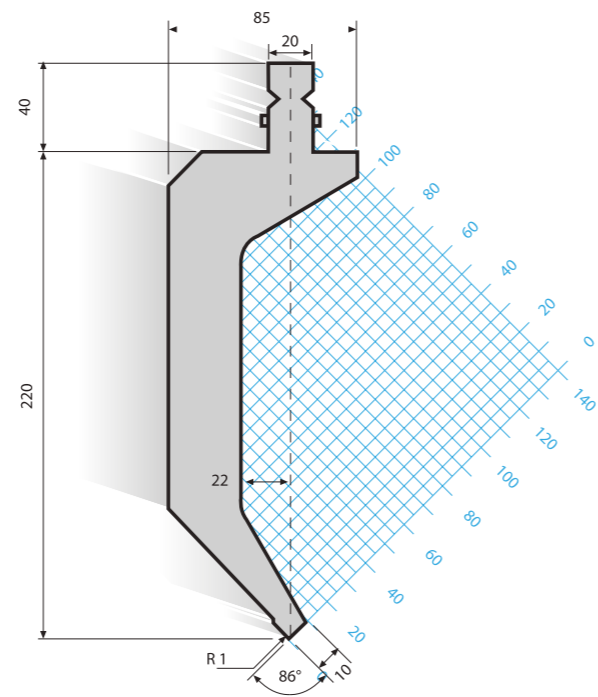

NOW

6w

AT SOONEST

24h

**1318 / T / 26° / R1**

SOLID 100 T/m ★★

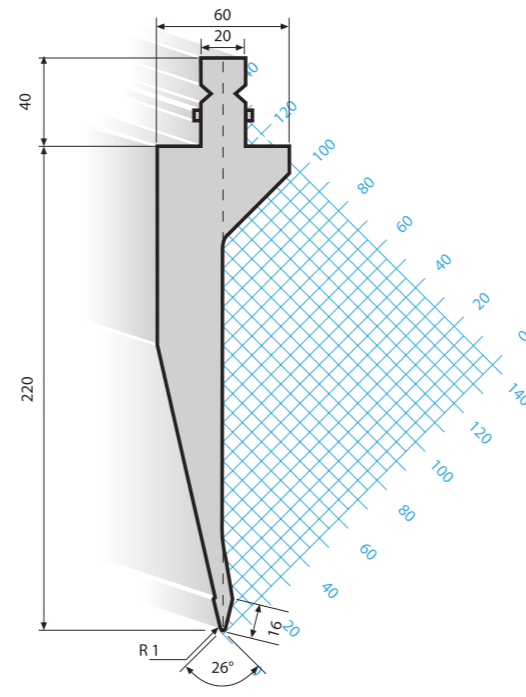

NOW

6w

AT SOONEST

24h

**1333 / T / 28° / R0.6**

B= 8 mm  
B= 10 mm  
B= 12 mm

SOLID 70 T/m ★★

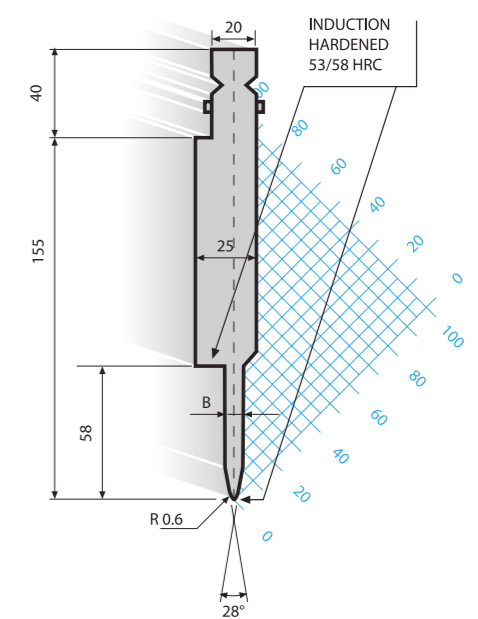

NOW

6w

AT SOONEST

24h

**1315 / T / 60° / R4**

SOLID 130 T/m ★★

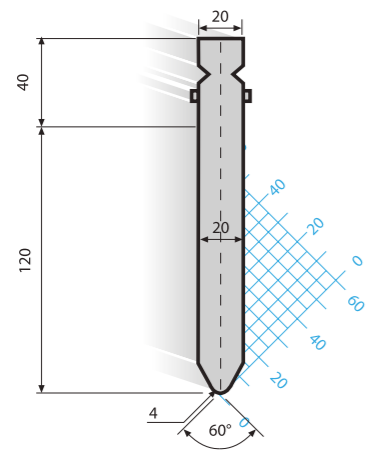

NOW

6w

AT SOONEST

24h

**2300 / T / 86° / V / H**



NOW

**6w**

AT SOONEST

**24h**

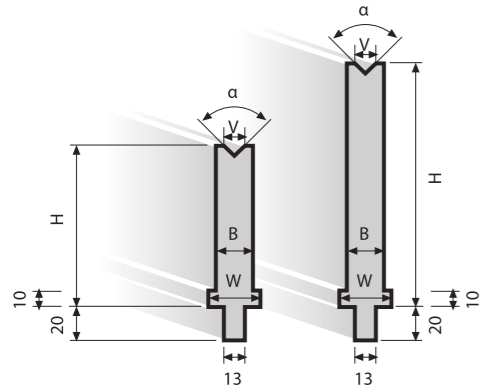

V	α	H (mm)	W (mm)	B (mm)	T / MT
6	86°	100	20	20	40
		100	20	10	24
		150	25	20	40
8	86°	100	20	20	40
		100	20	12	35
		150	25	20	40
10	86°	100	20	20	50
		100	20	14	38
		150	25	20	50
12	86°	100	25	25	50
		100	25	16	40
		150	25	25	50
16	86°	100	30	30	70
		150	30	30	70
		150	30	30	70
20	86°	100	30	30	70
		150	30	30	70
		150	30	30	70
24	86°	100	35	35	70
		150	35	35	70
		150	35	35	70
30	86°	100	45	45	75
		150	45	45	75
		150	45	45	75
40	86°	100	55	55	120
		150	55	55	120
		150	55	55	120
50	86°	100	75	75	150
		150	75	75	150
		150	75	75	150

**2300 / T / 80° / V / H**



NOW

**6w**

AT SOONEST

**24h**

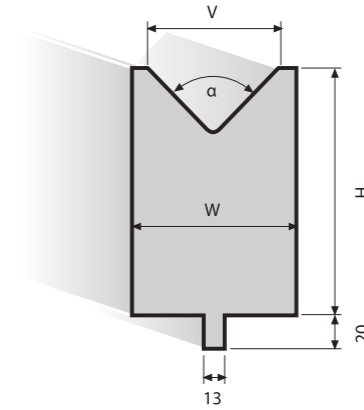

V	α	H (mm)	W (mm)	T / MT
60	80°	100	75	150
70	80°	100	85	150
80	80°	100	100	150
90	80°	120	110	150
100	80°	120	120	150

**2300 / T / 30° / V / H**



NOW

**6w**

AT SOONEST

**24h**

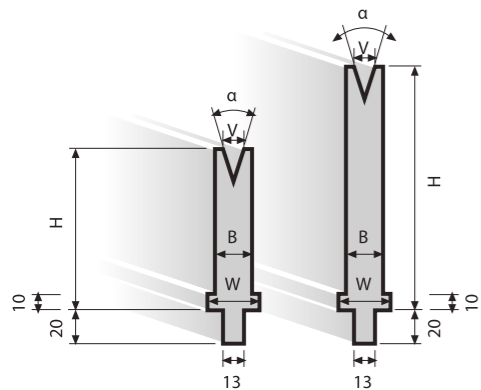

V	α	H (mm)	W (mm)	B (mm)	T / MT
6	30°	100	20	20	40
		100	20	12	17
		150	25	20	40
8	30°	100	20	20	40
		100	20	14	17
		150	25	20	40
10	30°	100	20	20	40
		100	20	16	20
		150	25	20	40
12	30°	100	25	25	40
		100	25	18	20
		150	25	25	40
16	30°	100	30	30	50
		150	30	30	50
		150	30	30	50
20	30°	100	35	35	60
		150	35	35	60
		150	35	35	60
24	30°	100	40	40	65
		150	40	40	65
		150	40	40	65

**2300 / T**

- U= 8 mm
- U= 10 mm
- U= 12 mm



NOW

**6w**

AT SOONEST

**24h**

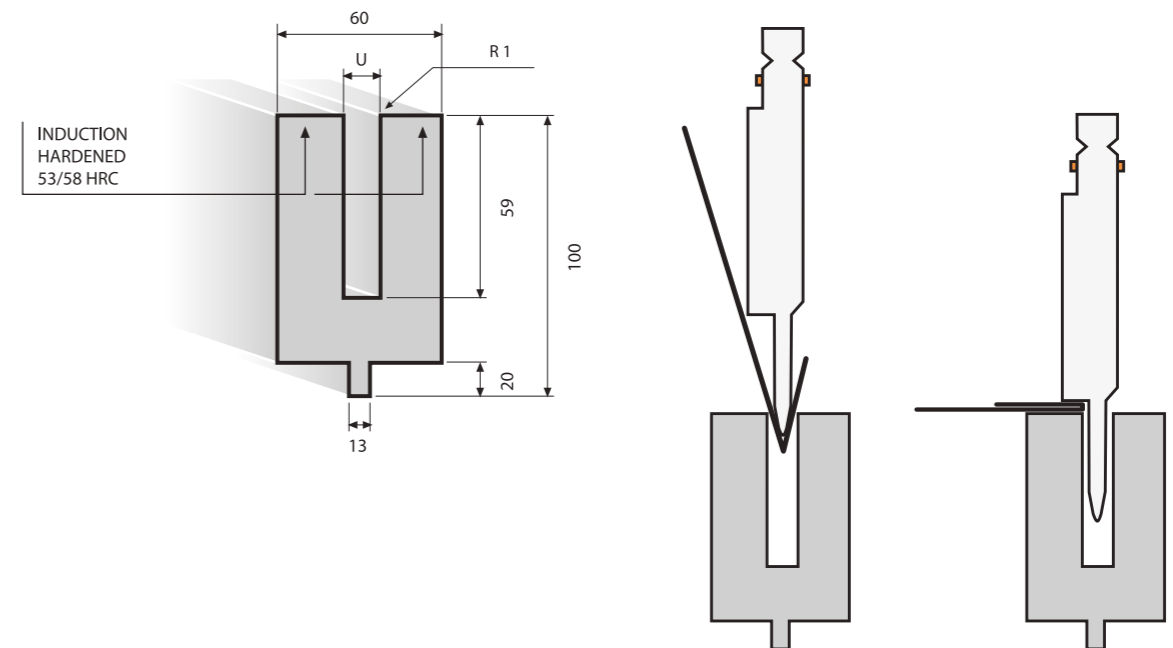

**Frazionatura standard per 1050 mm - Standard sectioning for 1050 mm  
Standard Sektionierung für 1050 mm - Fractionnement standard pour 1050 mm**

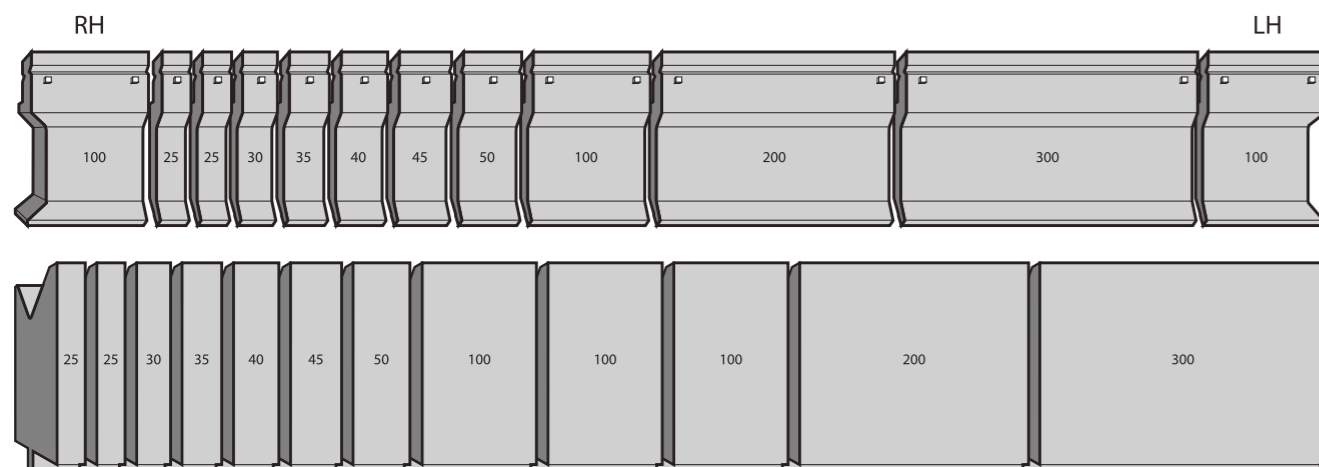

**MATRICI SPECIALI / SPECIAL DIES**

6w

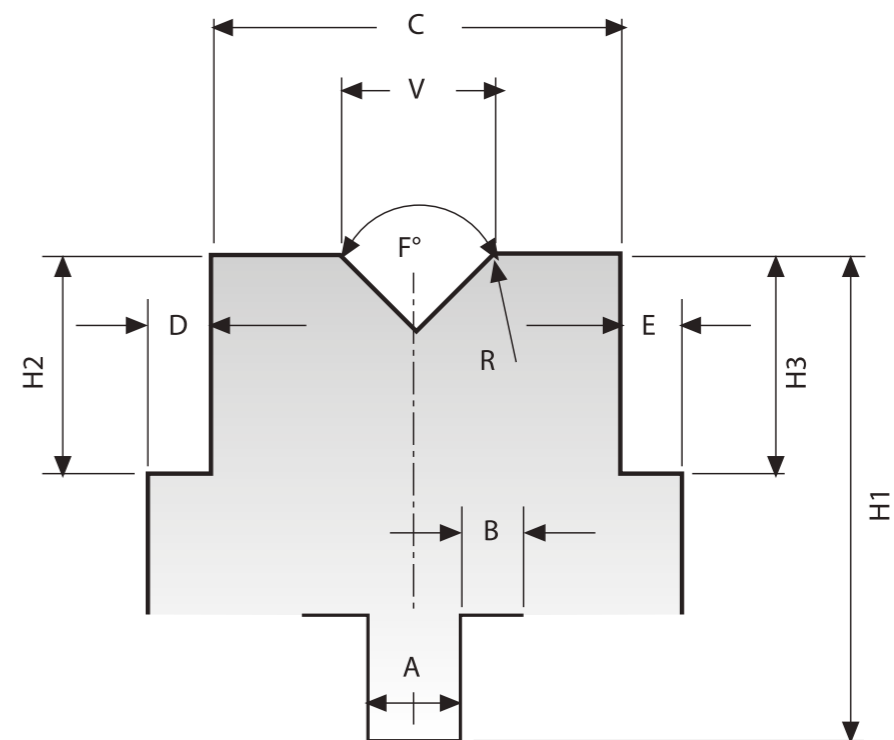

**Per ogni vostra richiesta di matrici speciali, vogliate indicare:**

- Altezza totale H1, h2 e H3;
- Dimensioni A, B, C, D, E e raggio R;
- Numero e disposizione delle cave da eseguire;
- Larghezza delle cave V;
- Gradi delle cave F°;
- Lunghezza e frazionati

For any enquiry on special dies, please state:

- Total height H1, h2 and H3;
- Dimensions A, B, C, D, E e radius R;
- Number and position of grooves;
- Width of grooves V;
- Degrees on grooves F°;
- Length and segmented

Bei Anfrage von Sondermatrizen nennen Sie uns bitte folgende Daten:

- Gesamte Höhe: H1, h2 und H3;
- Abmessung: A, B, C, D, E und Radius R;
- Anzahl und Position der V-Öffnungen;
- Öffnungsbreite: V;
- Öffnungsmaß: F°;
- Länge und Teilung

Pour exécution particulière, les valeurs suivantes sont nécessaires:

- Hauteur totale H1, h2 et H3;
- Dimensions A, B, C, D, E et rayon R;
- Nombre et position des "v";
- Grandeur du/des V;
- Angle du/des "v" F°;
- Longueur et fractionnement

PUNZONI SPECIALI / SPECIAL PUNCHES

6w

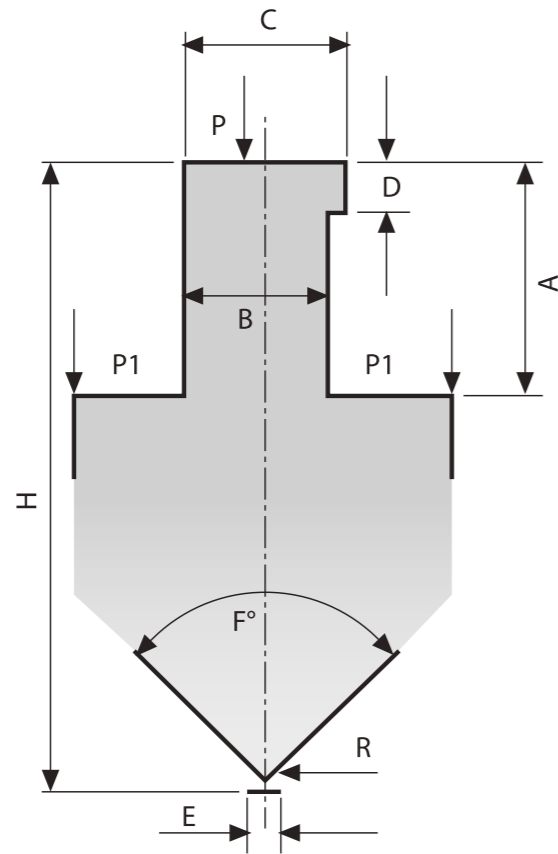

Per ogni vostra richiesta di punzoni speciali, vogliate indicare:

- Altezza totale H;
- Misure dell'attacco A, B, C, D;
- Gradi della punta F°;
- Misura del piano in punta E, oppure del raggio R;
- Se la pressa spinge in P o in P1;
- Lunghezza e frazionati

Bei Anfrage von Sonderstempeln nennen Sie uns bitte folgende Daten:

- Gesamte Höhe: H;
- Abmessungen: A, B, C, D;
- Winkel an der Spitze F°;
- Fase E oder Radius R;
- Biegekraft auf P oder P1;
- Länge und Teilung

For any enquiry on special tools, please state:

- Total height H;
- Dimensions of tongue A, B, C, D;
- Degrees of the nose F°;
- Measure of flat on E or radius R;
- Whether the press-brake presses on P or P1;
- Length and segmented

Pour exécution particulière, les valeurs suivantes sont nécessaires:

- Hauteur totale H;
- Dimensions de la fixation A, B, C, D;
- Angle de la pointe F°;
- Plat E ou rayon R de la pointe;
- Force de pliage en P ou P1;
- Longueur et fractionnement

TABELLA DI PIEGATURA - BENDING TABLE  
ABKANTTABELLE - ABAQUE DE PLIAGE

V	R	B	S	0.5	0.8	1	1.2	1.5	1.8	2	2.5	3	4	5	6	8	10	12	15	20	25												
4	0.7	2.6		4	10.5																												
6	1	4		3.5	6	10	13																										
8	1.5	5.2		2	5.5	8	11.5	18																									
10	1.7	6.5			4.1	6.5	9.5	14.5	21	26																							
12	2	7.8				5.5	8	12	17.5	21.5	33.5																						
16	2.7	10.4					6	9	13	16	25	36																					
20	3.4	13						7.5	10.5	13	20	29	52																				
25	4.2	16							8.5	10.5	16	23	41	64																			
30	5	20									14	19	34	54	77																		
35	6	23										17	30	46	66																		
40	7	26											15	26	40	58	103																
45	7.5	29												23	36	52	91																
50	8.5	32													21	32	46	82	128														
55	9	36														30	42	75	117														
60	10	39															27	39	69	107													
65	10.8	42																25	36	63	99	142											
70	11.7	45																	33	59	92	132											
75	12.5	49																		31	55	86	123										
80	13.5	52																			29	52	80	116	180								
85	14	55																				49	76	109	170								
90	15	58																					46	71	103	160							
100	17	65																						41	64	93	144	256					
110	18.5	71																								59	84	131	233				
120	20	78																									54	77	120	213	333		
140	24	91																											66	103	183	286	
170	29	110																												55	85	151	235

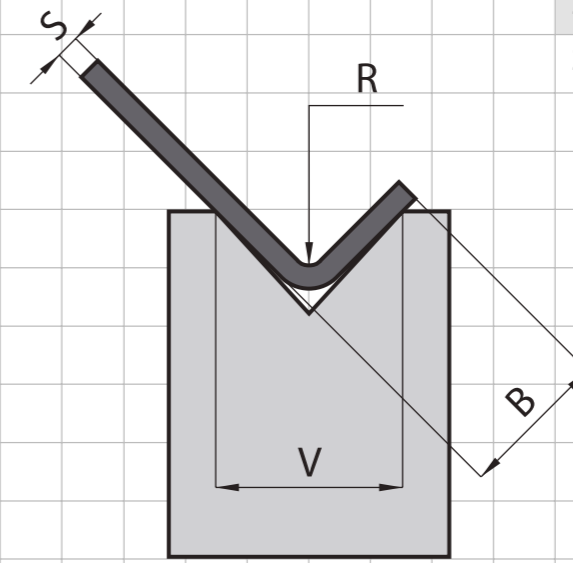

V = (mm)  
R = (mm)  
B = (mm)  
S = (mm)  
F = (KN/m)

Forza di piegatura al metro per materiale con resistenza di 400 N/mm<sup>2</sup>. Per resistenza di 800 N/mm<sup>2</sup>(Inox) moltiplicare la forza per 2.

Bending force per meter for material tensile strength of 400 N/mm<sup>2</sup>. For tensile strength of 800 N/mm<sup>2</sup>(Inox) multiply the bending force by 2.

Biegekraft pro Meter für eine Materialfestigkeit von 400 N/mm<sup>2</sup>. Für eine Festigkeit von 800 N/mm<sup>2</sup>(Inox), bitte die Biegekraft verdoppeln.

Force de pliage par mètre pour une matière ayant une résistance de 400 N/mm<sup>2</sup>. Pour une résistance de 800 N/mm<sup>2</sup>(Inox) multiplier la force par 2.

## Notes

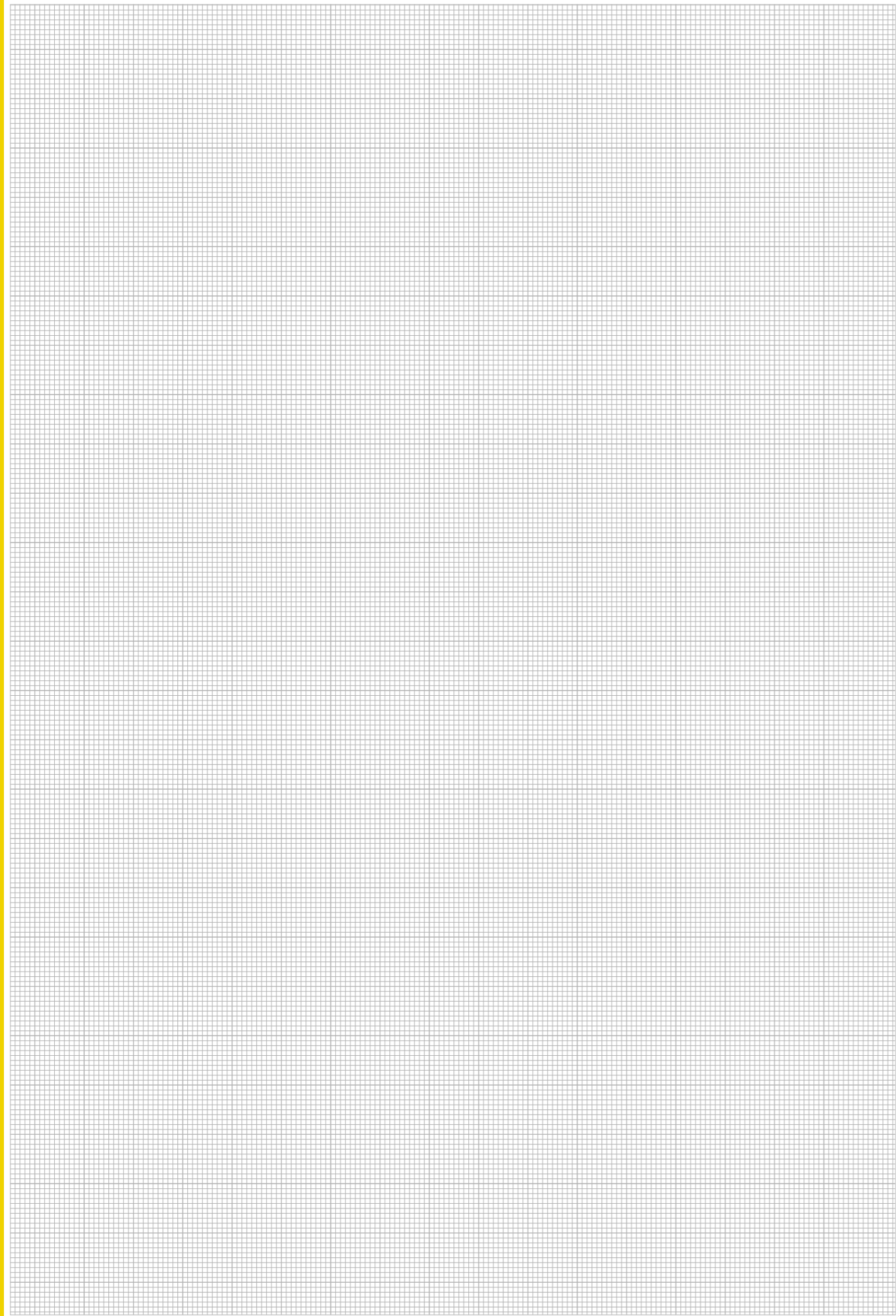

## Notes

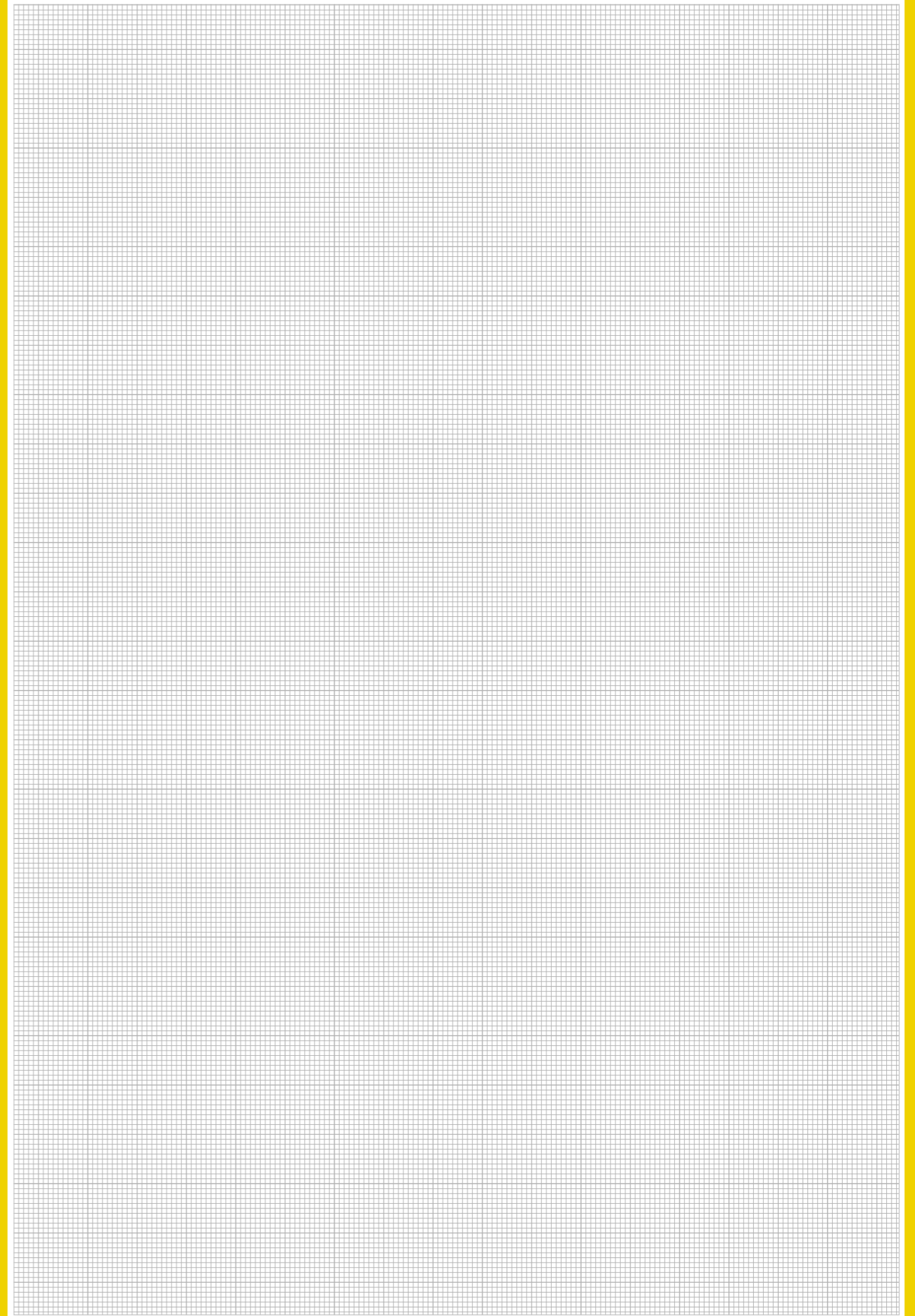



## SAFETY WARNING

**ATTENZIONE!** Gli utensili per presse piegatrici esposti in questo catalogo dovranno essere rigorosamente utilizzati secondo le norme di sicurezza in vigore in Europa o nei Paesi d'esportazione e di utilizzazione. Questi utensili non dovranno essere utilizzati su macchine prive di sistema di sicurezza atto a prevenire l'introduzione delle mani o di altra parte del corpo nello spazio aperto tra un utensile e l'altro. L'utilizzatore di tali utensili è responsabile del funzionamento e del rispetto delle norme di sicurezza atte a prevenire possibili incidenti.

**SAFETY WARNING!** The press brake tools shown in this catalogue should be used in strict compliance with all European safety standards.

Press brake tools are never intended to be used in equipment without a means provided for preventing any and all body parts from entering or remaining in the die space at any time.

It is the user's responsibility to make certain that point of operation protection is effective and that all applicable safety requirements are met.

**SICHERHEITSHINWEIS!** Die in diesem Katalog gezeigten Abkantwerkzeuge dürfen nur entsprechend den gültigen Sicherheitsbestimmungen im Land des Anwenders eingesetzt werden.

Abkantwerkzeuge dürfen nur in Maschinen eingesetzt werden, die Schutzvorrichtungen aufweisen, die den Körper oder Körperteile vor Quetschungen und Scherungen zu jedem Zeitpunkt wirksam schützen.

Die Verantwortung dafür liegt beim Anwender, der sicher stellen muss, dass alle notwendigen Sicherheitssysteme an der Maschine angebaut und funktionstüchtig sind.

**MISE EN GARDE DE SECURITE!** Les outils de pliage figurant dans ce catalogue doivent être utilisés strictement selon les lois de sécurité en vigueur localement et dans les pays d'utilisation.

Ces outils ne doivent pas être utilisés dans des machines qui ne possèdent pas de sécurité afin de protéger l'utilisateur contre la possibilité que ses mains ou autres parties de son corps puissent se trouver entre les outils.

L'utilisateur est responsable du fonctionnement de la surveillance de sécurité des points d'outils et autres sécurités sur la machine.

**EURAM** si riserva il diritto di modificare od annullare in qualsiasi momento specifiche di produzione, materiali o prezzi senza preavviso o particolari obblighi.

**EURAM** reserves the right to discontinue or change at any time specifications, materials, or prices without prior notice or obligation.

**EURAM** behält sich jederzeit vor, ohne Verpflichtung und Vorankündigung Änderungen der Spezifikationen, Materialien und Preise der Abkantwerkzeuge vorzunehmen.

**EURAM** se réserve à tout moment le droit, sans notice préalable ou obligation, d'arrêter ou de changer la spécification, la matière ou les prix.



**TOOLING DISTRIBUTED IN:**

ARGENTINA - AUSTRALIA - AUSTRIA  
BELGIUM - BRASIL - BULGARIA  
CANADA - CHILE - CHINA - COLOMBIA - CROATIA - CZECH REPUBLIC  
DENMARK - EQUADOR - ESTONIA  
FINLAND - FRANCE  
GERMANY - GREECE  
HONG KONG - HUNGARY  
ICELAND - INDIA - IRAN - IRELAND - ITALY - JORDAN  
KENYA - KOREA - KUWAIT - LATVIA - LETTONIA - MEXICO  
NETHERLANDS - NEW ZELAND - NIGERIA - NORWAY  
PHILIPPINES - POLAND - PORTUGAL  
ROMANIA - RUSSIA  
SAUDI ARABIA - SERBIA - SINGAPORE - SYRIA - SLOVAKIA - SLOVENJA  
SOUTH AFRICA  
SPAIN - SWEDEN  
SWITZERLAND  
TAIWAN (R.O.C.) - THAILAND - TRINIDAD & TOBAGO - TURKEY  
UKRAINA - UNITED KINGDOM  
UNITED STATES OF AMERICA  
VENEZUELA

**E U R A M**

EURAM Italiana srl - 43122 Parma (ITALY) - 13 A, Traversante S. Leonardo  
Ph: +39 0521 776545 - Fax: +39 0521 776353 - e-mail: euram@euram.it - internet: www.euram.it





# E U R A M

**EURAM Italiana srl** - 43122 Parma (ITALY) - 13 A, Traversante S. Leonardo  
**Ph:** +39 0521 776545 - **Fax:** +39 0521 776353 - **e-mail:** [euram@euram.it](mailto:euram@euram.it) - **internet:** [www.euram.it](http://www.euram.it)